

POWER7 — Smarter Systems for Smarter Planet

Bharvi Parikh
IBM Technical Sales
bharvi@us.ibm.com
860.680.3952

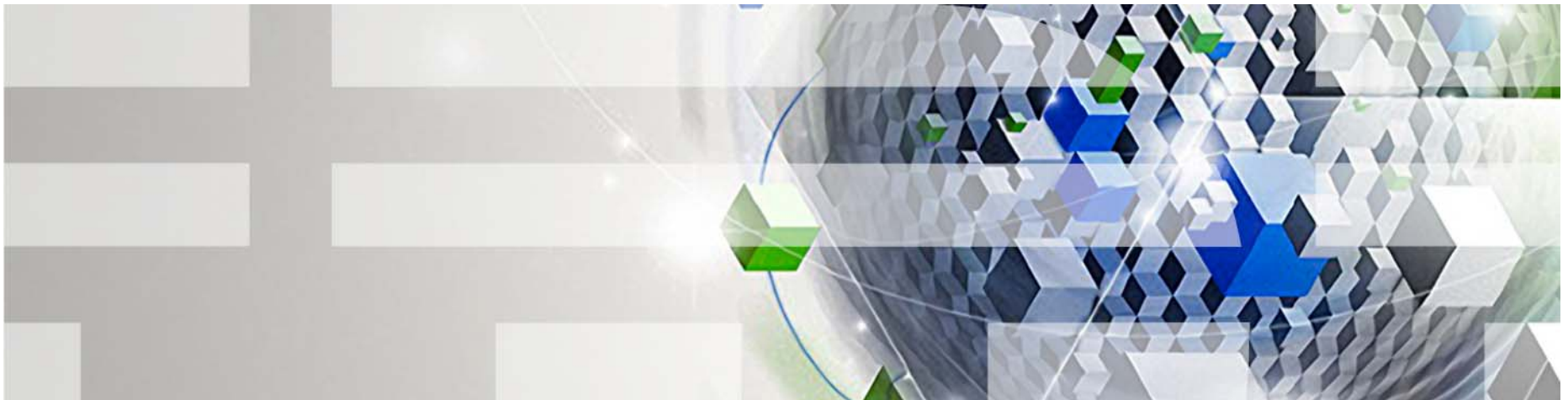

POWER7 750 won the Jeopardy Game

- **IBM Watson** represents the latest in a long line of groundbreaking innovations from IBM
- Watson can understand the meaning and context of human language, and rapidly process information to find precise answers to complex questions
- What's next for Watson?
 - Project with Columbia University and Maryland School of Medicine to provide healthcare and life sciences diagnostic assistance
 - Research agreement with Nuance Communications to develop and apply Watson to healthcare
 - Other fields of investigation range from enterprise knowledge management to IT help desk

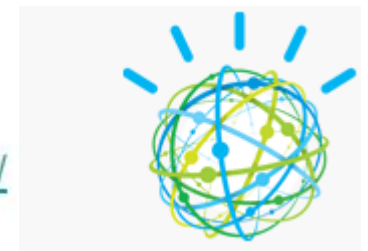

To learn more about IBM Watson: <http://www.ibm.com/watson/>

POWER7 Processor

- Cores:
 - **2.4 GHz to 4.25 GHz**
 - Up to 8 Intelligent Cores / chip (socket)
 - 4 and 6 Intelligent Cores available on some models
 - 12 execution units per core
 - **Out of order execution**
 - **4 Way SMT per core**
 - 32 threads per chip
 - L1 – 32 KB I Cache / 32 KB D Cache per core
 - L2 – 256 KB per core
- Chip:
 - **32MB Intelligent L3 Cache on chip**
- Memory:
 - Dual DDR3 Controllers
 - **100 GB/s sustained Memory bandwidth / chip**
- Scalability:
 - Up to 32 Sockets
 - 360 GB/s peak SMP bandwidth / chip
 - 590 GB/s peak I/O bandwidth / chip
 - Up to 20,000 coherent operations in flight
- Energy:
 - Aggressive processor Nap & Sleep modes
 - 10% “Over clock” when thermals are good

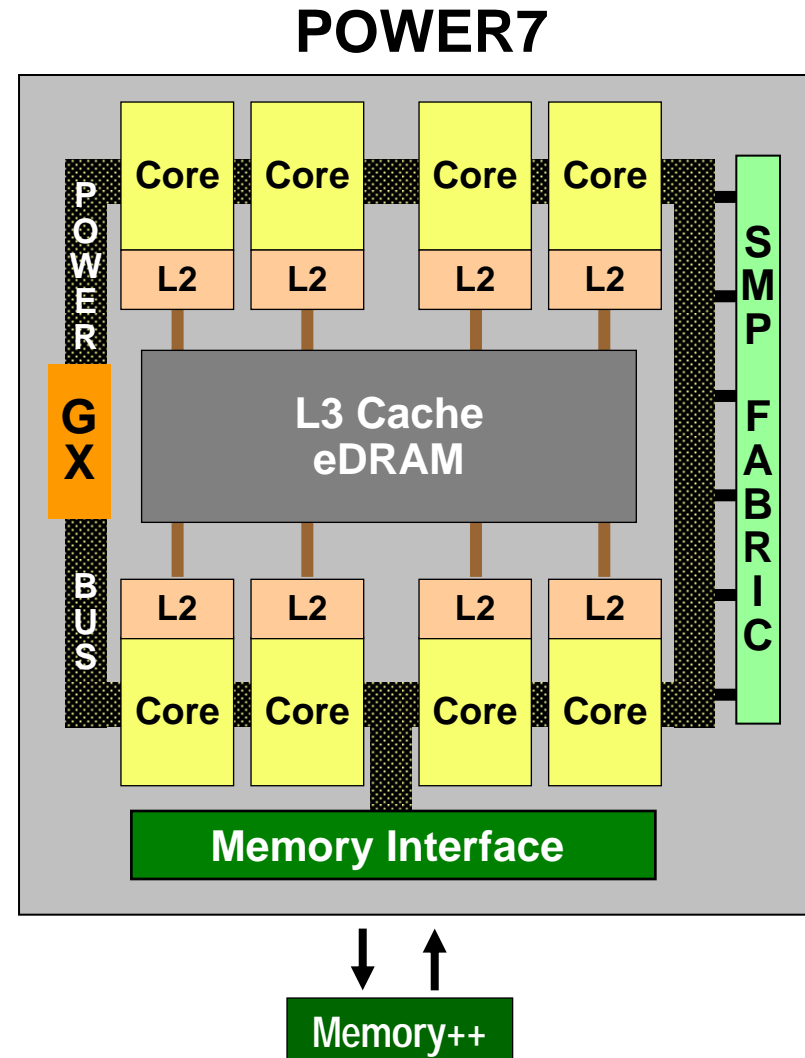

POWER7 Systems Portfolio

Major Features:

- Modular systems with linear scalability
- PowerVM Virtualization
- Physical and Virtual Management
- Roadmap to Continuous Availability
- Binary Compatibility
- Energy / Thermal Management



4/8/16/32 cores
64 GB/128 GB/256 GB



4-16 cores
128 GB GB

Power 710/730

4-16 cores
256 GB GB

Power 720/740

32 cores
512 GB

Power 750

Power 755

32 cores
256 GB

64 cores
2 TB

Power 770

64 cores
2 TB

Power 780

256 cores
8 TB

Power 795

HPC



Power System 770



4U x 32 inches Depth



Power System 770		
Processor Technology	6 Cores @ 3.55 GHz 8 Cores @ 3.1 GHz	
L3 Cache	On Chip	
Redundant Power & Cooling	Yes	
Redundant Server Processor	Yes / Two Enclosure minimum	
Redundant Clock	Yes / Two Enclosure minimum	
Concurrent Add Support	Yes	
Concurrent Service	Yes	
System Unit	Single Enclosure	4 Enclosures
Processors	2 Sockets	8 Sockets
DDR3 Memory (Buffered)	Up to 512 GB	Up to 2 TB
SAS/SSD SFF Bays (CEC)	6	24
DVD-RAM Media Bays	1 Slim-line	4 Slim-line
SAS / SATA Controller	2 / 1	8 / 4
PCIe (CEC)	6 PCIe	24 PCIe
GX++ Slots (12X DDR)	2	8
Integrated Ethernet	Std: 1 x Quad 1Gb Opt: 1 x Dual 10Gb + Dual 1 Gb	Std: 4 x Quad 1Gb Opt: 4 x Dual 10Gb + Dual 1Gb
USB	3	12
12X I/O Drwrs	Max: 4 PCIe, 8 PCI-X	Max: 16 PCIe, 32 PCI-X

Active Memory Expansion

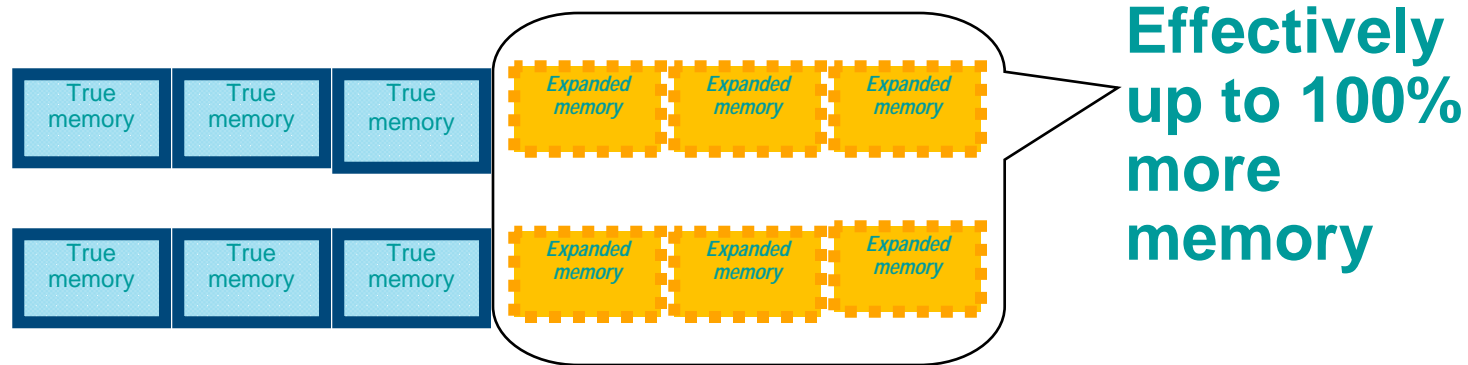

- POWER7 advantage
- Expand memory beyond physical limits
- More effective server consolidation
 - Run more application workload / users per partition
 - Run more partitions and more workload per server

Capacity on Demand for IBM Power Systems

Capacity Upgrade on Demand

- Upgrade system with processors and/or memory
- No special contracts, no required monitoring (no ability to turn off the capacity)
- Purchase agreement

On/Off Capacity on Demand

- Temporary use of requested number of processors or amount of memory
- Client selects the capacity and activates the resource (registered system)
- Capacity can be turned on and off by the client
- Information captured by IBM (or reported to IBM)
- Rental agreement

Utility Capacity on Demand

- Processor resources only / **Measured by processor minutes**
- Capacity can be turned on and off by the client
- Prepaid or post pay
- Requires AIX V5.3 and PowerVM

Trial Capacity on Demand

- Allow clients to test the effects of additional processors and/or memory
- Partial or total activation of processors and memory
- Resources available for fixed time
- No formal commitment required

Dynamic Processor Sparing

- Automated replacement of de-allocated processors
- Unassigned or inactive processors

SAP Performance

SAP users on SAP SD 2 Tier

Source: <http://www.sap.com/solutions/benchmark/sd2tier.epx>

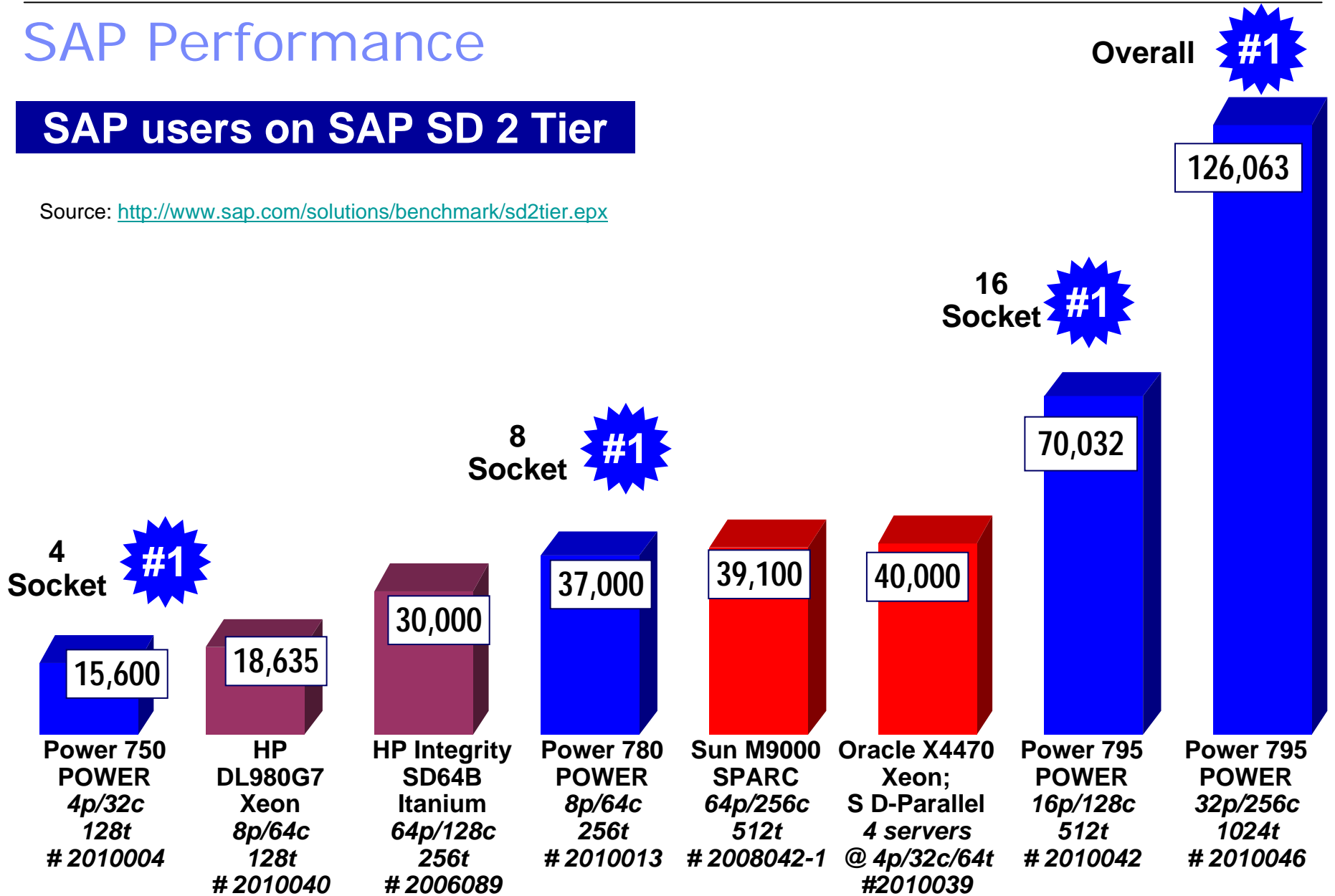

Virtualization (PowerVM)

Hardware and software that delivers industry-leading virtualization on IBM POWER processor-based processors for UNIX, Linux and i5/OS customers



Micro-Partitioning
Subsystems



Workload Partitions
Live Application Mobility



PowerVM Editions feature

- Logical Partitioning
- Micro-Partitioning™
- Virtual I/O Server
- Active Memory Sharing
- Live Partition Mobility
- Lx86



PowerVM is the umbrella branding term for Power Systems Virtualization (Logical Partitioning, Micro-Partitioning, POWER Hypervisor, Virtual I/O Server, etc.)

Power Systems Virtualization with PowerVM

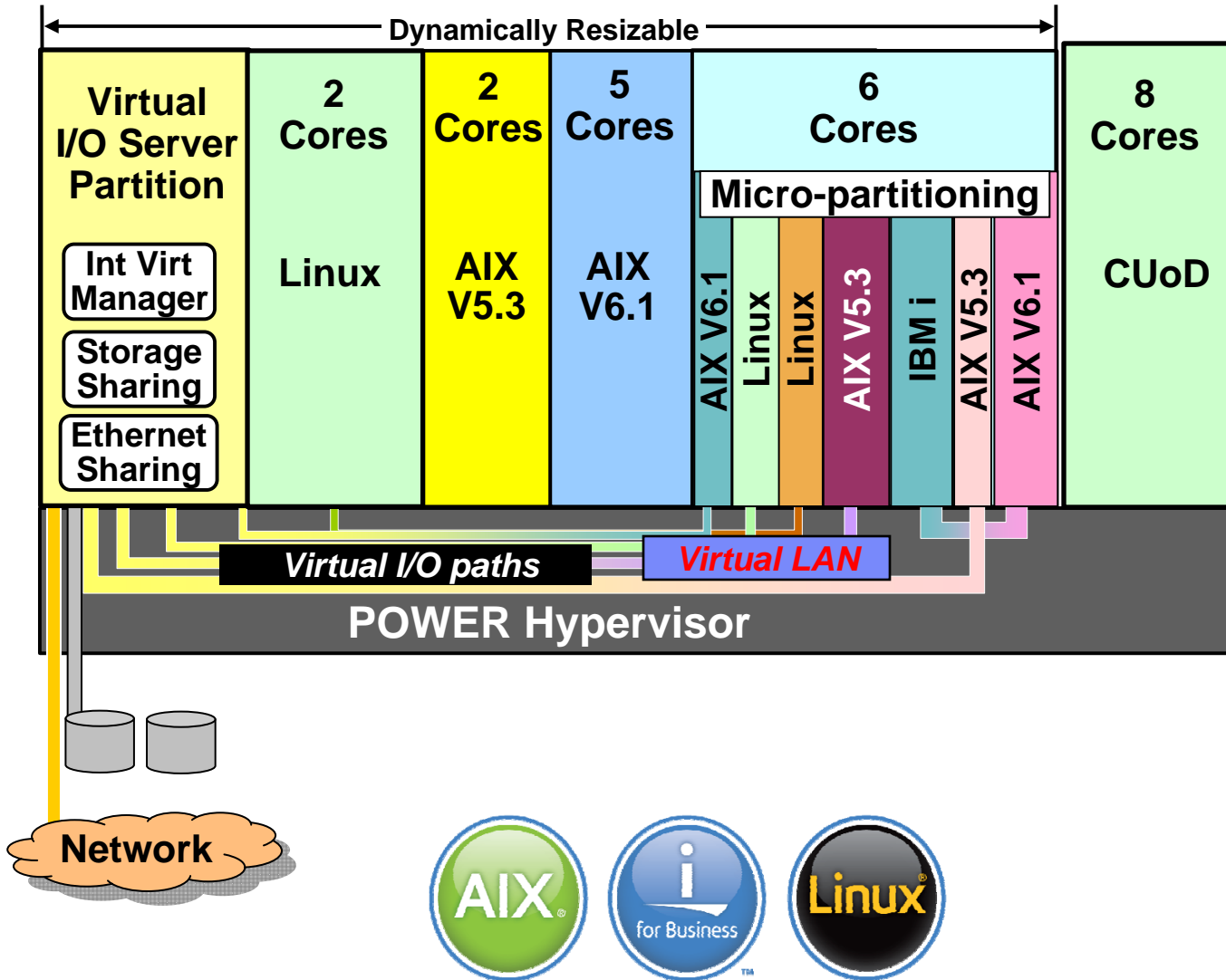

Micro-Partitioning Feature

- Share processors across multiple partitions
- Minimum partition 1/10th core
- 1024 partition maximum
- AIX V5.3/6.1, Linux, & IBM i

Active Memory Sharing

- Share memory across LPAR's
- Over commit memory
- Mix of dedicated and shared memory LPAR's

Virtual I/O server

- Shared Ethernet
- Shared SCSI & Fibre Channel attached disk subsystems

Benefits

- Lower HW and SW counts
- Reduced Environmental Cost
- Rapid service provisioning

PowerVM Live Partition Mobility with POWER6

Allows migration of a running LPAR to another physical server

- ✓ Reduce impact of planned outages – less work on weekends!
- ✓ Relocate workloads to enable growth
- ✓ Provision new technology with no disruption to service
- ✓ NEW: Source and Target Servers managed from unique HMCs

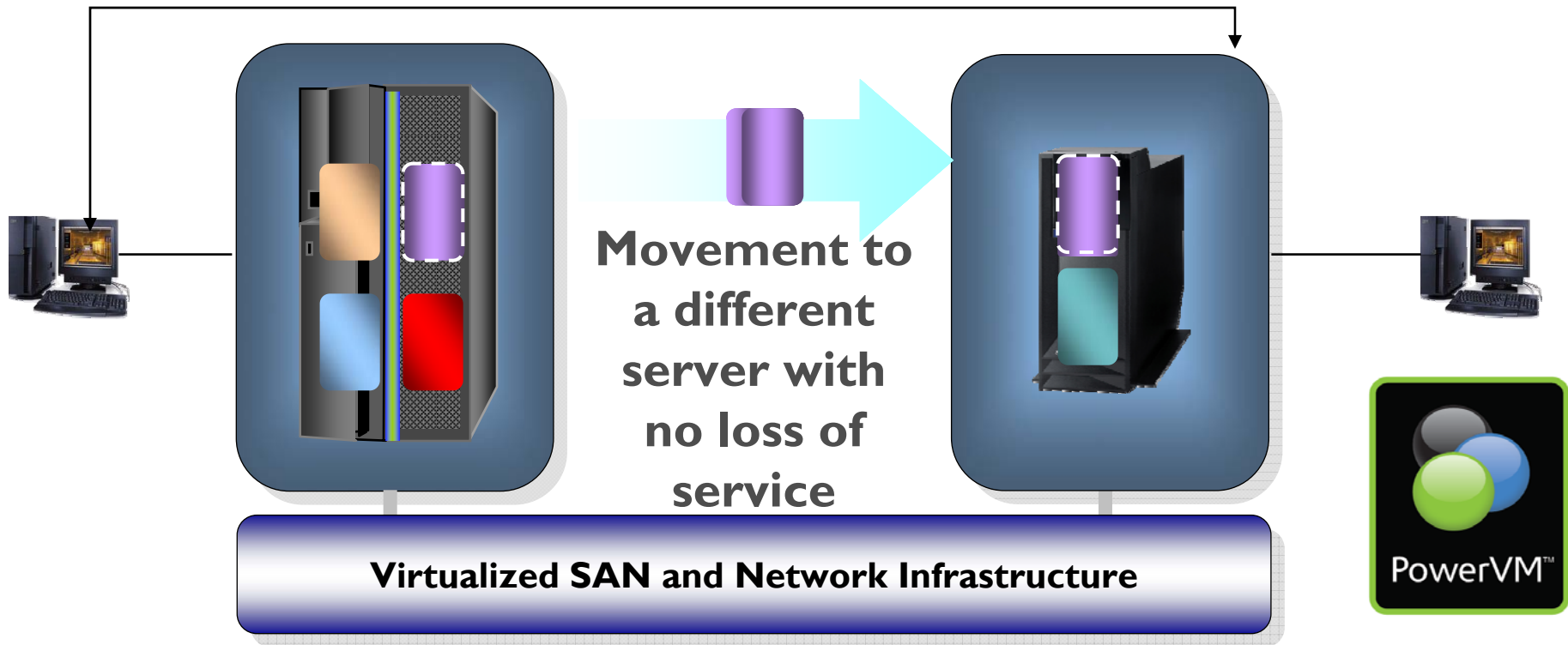

PowerVM Storage Pools

Extending Storage Virtualization Layer
Beyond a Single System

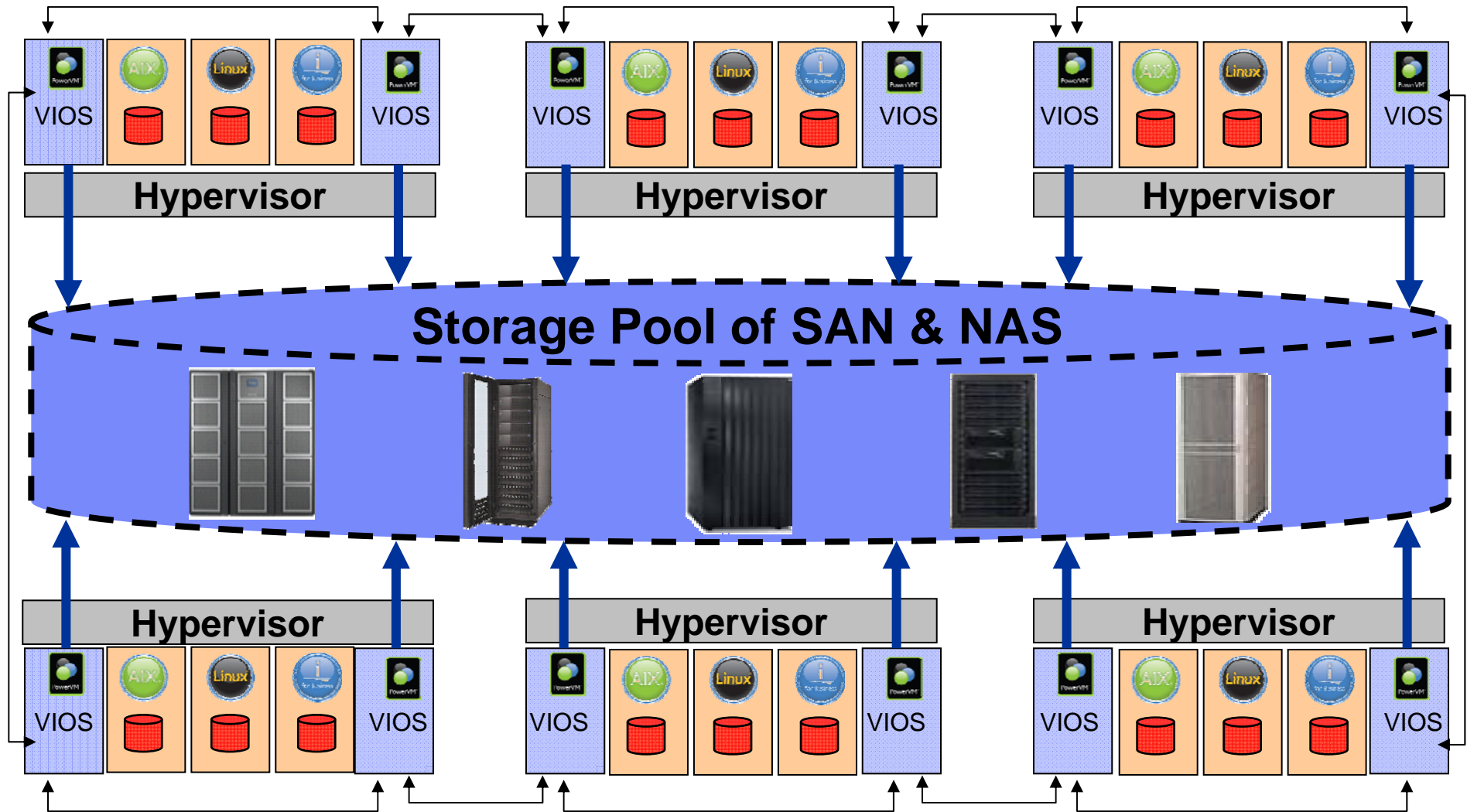

AIX Evolution – Over 20 years of Progress

1986-1992 1994-1996 1997-1999 2001 2002 2004-2007 2010

AIX/6000



AIX V2 & V3
Establishment in the market:
 - RISC Support
 - UNIX credibility
 - Open Sys. Stds..
 - Dynamic Kernel
 - JFS and LVM
 - SMIT

AIX V3.2.5
Maturity:
 - Stability
 - Quality

AIX V4.1/4.2
SMP Scalability:
 - POWERPC spt.
 - 4-8 way SMP
 - Kernel Threads
 - Client/Server pkg
 - NFS V3
 - CDE
 - UNIX95 branded
 - NIM
 - > 2GB filesystems
 - HACMP Clustering
 - POSIX 1003.1, 1003.2, XPG4
 - Runtime Linking
 - Java 1.1.2

AIX V4.3
Higher levels of scalability:
 - 24-way SMP
 - 64-bit HW support
 - 96 GB memory
 - UNIX98 branded
 - TCP/IP V6
 - IPsec
 - Web Sys. Mgr.
 - LDAP Dir. Server.
 - Workload Mgr
 - Java JDT/JIT
 - Direct I/O
 - Alt. Disk Install
 - Exp/Bonus CDs

AIX 5L V5.1/5.2
Flexible Resource Management:
 - POWER4+ spt.
 - Dynamic LPAR
 - Dynamic CUoD
 - New 64bit kernel
 - 512GB mem
 - JFS2
 - 16 TB filesystems
 - UNIX03 branded
 - Concurrent I/O
 - MultiPath I/O
 - Flex LDAP Client
 - XSSO PAM spt

AIX 5L V5.3
Advanced Virtualization:
 - POWER5 support
 - 64-way SMP
 - SMT
 - MicroPartitions™
 - Virt I/O Server
 - Partition Load Mgr
 - NFS Version 4
 - Adv. Accounting
 - Scaleable VG
 - JFS2 Shrink
 - SUMA
 - SW RAS features
 - POSIX Realtime

AIX 6
Enterprise RAS:
 -POWER6 support
 -Workload Partitions
 -Application Mobility
 -Continuous Avail.
 -Storage Keys
 -Dynamic tracing
 -Software FFDC
 -Recovery Rtns
 -Concurrent MX
 -Trusted AIX
 -RBAC
 -Encrypting JFS2
 -AIX Security Expert
 -Director Console

AIX 7
Future of UNIX:
 -256 core/1024 tread scalability
 -POWER7 Exploitation
 -Domain based RBAC
 - AIX Profile Manager
 -WPAR enhancements
 -AIX 5.2 in a WPAR
 -PowerVM virtualized storage
 -LVM SSD support
 -Terabyte segment

Open Systems Workstations
 Uni-processor

Distributed Client-Server
 4-8 way SMP

Network Centric Computing
 24-way SMP

e-Business Computing
 32-way SMP

On Demand Business
 64/256-way SMT

New Enterprise Data Center
 1024-way SMT4

Smarter Planet
 1024-way SMT4

AIX 6 Workload Partitions (WPARs)



- S/W Partitioned system capacity
 - Each WPAR gets a regulated share of the processor and memory resources
 - Each WPAR has separate network and filesystems and many system services
- Separate Administrative control
 - Each partition is a separate administrative and security domain
- Shared system resources
 - I/O Devices
 - Processor & Memory
 - Operating system
 - Shared Library and Text
- WPAR Types: System and Application
 - System has own copy of /, /tmp, /var, /home
 - Application uses Global filesystems
- Benefits
 - Separate regions of application space within a single AIX image
 - Improved administrative efficiency
 - Reduced no. of OS images to administer and maintain
 - System commands are WPAR enabled



AIX Enterprise Edition

AIX Enterprise Edition is a single offering that brings together AIX with key service management capabilities that are designed to:

- *Improve availability through access to relevant real-time information and predictive monitoring to avoid future problems*
- *Enhance operational efficiency through visualization of resources and centralized deployment and management of virtualized AIX environments*
- *Provide accurate assessment of system resource usage*

AIX Enterprise Edition includes:

- AIX 7 or AIX 6
- WPAR Manager
- Systems Director Enterprise Edition
 - **IBM System Director**
 - **Active Energy Manager**
 - **VMControl (including Image Management & System Pools)**
 - **Network Control**
 - **Transition Manager for HP® SIM**
 - **Service and Support Manager**
 - **IBM Tivoli Monitoring**
 - **Tivoli Application Dependency Discovery Manager (TADDM)**



© 2010 IBM Corporation

POWER7 — Power your Enterprise



Thank You!

