



System z10 – The “Other” Stuff CMG Canada – April 2008



Gord Neill
System z
Advanced Technical Support
IBM Canada Ltd
gneill@ca.ibm.com



IBM Systems

© 2007 IBM Corporation

Agenda

- **Z10 Performance**
 - Guidance
 - Capacity Provisioning
- **z/OS V1.10 Preview**
 - Availability
 - Performance
 - Security
 - Management
 - Z10 Support
- **DASD Mirroring**
 - Basic Hyperswap

Trademarks

The following are trademarks of the International Business Machines Corporation in the United States and/or other countries.

AnyNet*	HyperSwap	PR/SM	Tivoli*
CICS*	IBM*	PrintWay	Tivoli Storage Manager
DB2*	IBM eServer	RACF*	TotalStorage*
DFSMSdfp	IBM logo*	Redbooks*	VSE/ESA
DFSMSHsm	IMS	RMF	VTAM*
DFSMSrmm	InfoPrint*	S/390*	WebSphere*
DFSORT	Language Environment*	Sysplex Timer*	z/Architecture*
DRDA*	Multiprise*	System Storage	z/OS*
DS6000	NetView*	System z	z/VM*
DS8000	OMEGAMON*	System z9	z/VSE
ESCON*	Open Class*	SystemPac*	zSeries*
FICON*	OS/390*	Tivoli*	
GDPS*	Parallel Sysplex*		
HiperSockets			

* Registered trademarks of IBM Corporation

The following are trademarks or registered trademarks of other companies.

Java and all Java-related trademarks and logos are trademarks of Sun Microsystems, Inc., in the United States and other countries

Linux is a trademark of Linus Torvalds in the United States and other countries..

UNIX is a registered trademark of The Open Group in the United States and other countries.

Microsoft and Excel are registered trademarks of Microsoft Corporation in the United States and other countries.

* All other products may be trademarks or registered trademarks of their respective companies.

Notes:

Performance is in Internal Throughput Rate (ITR) ratio based on measurements and projections using standard IBM benchmarks in a controlled environment. The actual throughput that any user will experience will vary depending upon considerations such as the amount of multiprogramming in the user's job stream, the I/O configuration, the storage configuration, and the workload processed. Therefore, no assurance can be given that an individual user will achieve throughput improvements equivalent to the performance ratios stated here.

IBM hardware products are manufactured from new parts, or new and serviceable used parts. Regardless, our warranty terms apply.

All customer examples cited or described in this presentation are presented as illustrations of the manner in which some customers have used IBM products and the results they may have achieved. Actual environmental costs and performance characteristics will vary depending on individual customer configurations and conditions.

This publication was produced in the United States. IBM may not offer the products, services or features discussed in this document in other countries, and the information may be subject to change without notice. Consult your local IBM business contact for information on the product or services available in your area.

All statements regarding IBM's future direction and intent are subject to change or withdrawal without notice, and represent goals and objectives only.

Information about non-IBM products is obtained from the manufacturers of those products or their published announcements. IBM has not tested those products and cannot confirm the performance, compatibility, or any other claims related to non-IBM products. Questions on the capabilities of non-IBM products should be addressed to the suppliers of those products.

Prices subject to change without notice. Contact your IBM representative or Business Partner for the most current pricing in your geography.

Agenda



- **Z10 Performance**
 - Guidance
 - Capacity Provisioning
- **z/OS V1.10 Preview**
 - Availability
 - Performance
 - Security
 - Management
 - Z10 Support
- **DASD Mirroring**
 - Basic Hyperswap

LSPR Single Image Capacity Ratios 16way: z9 EC versus z990

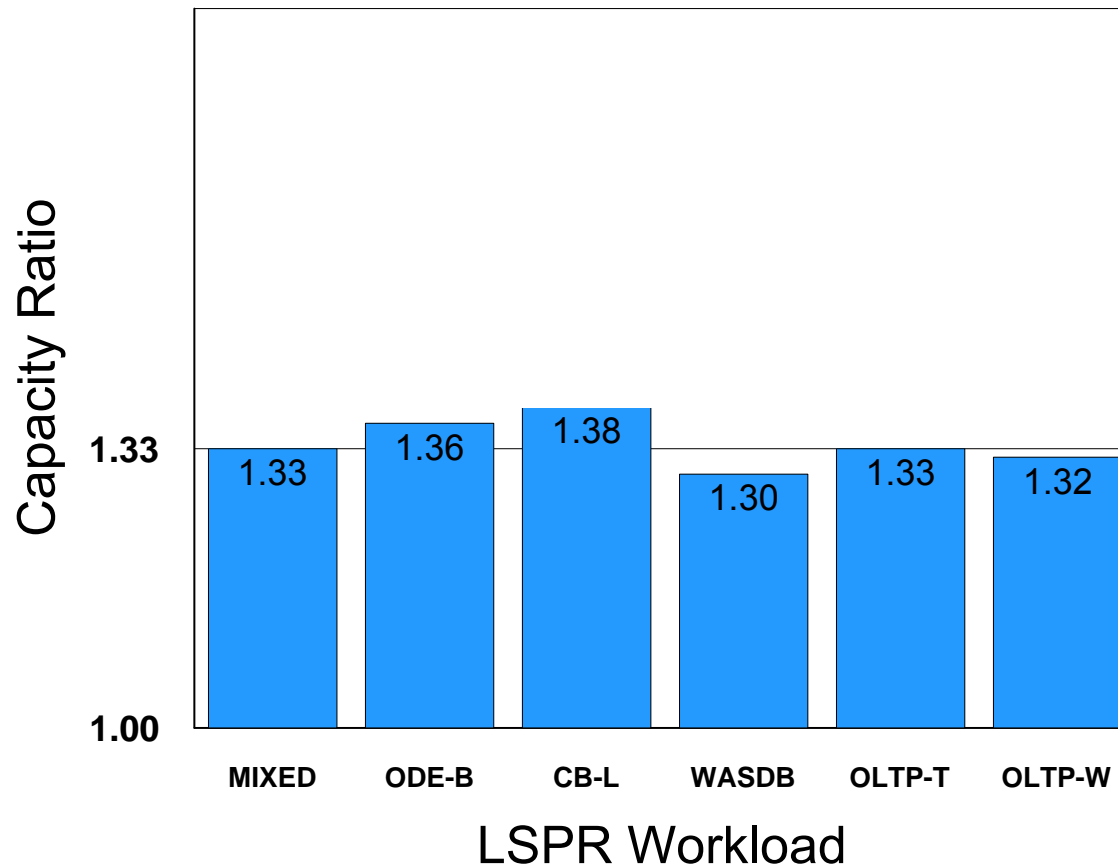

System Design + Workload Characteristics

Variation from Average: sometimes large
Example: z9 EC to z10 EC

- z9 EC
 - ▶ CPU
 - 1.7 Ghz
 - superscalar
 - ▶ Caches
 - L1 private 256k i, 256k d
 - L2 shared 40 mbs / book
 - book interconnect: ring

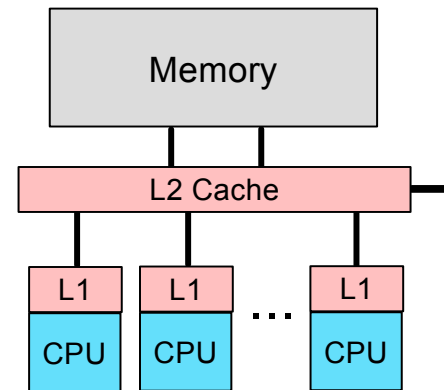

LSPR Single Image Capacity Ratios 16way: z10 EC versus z9 EC

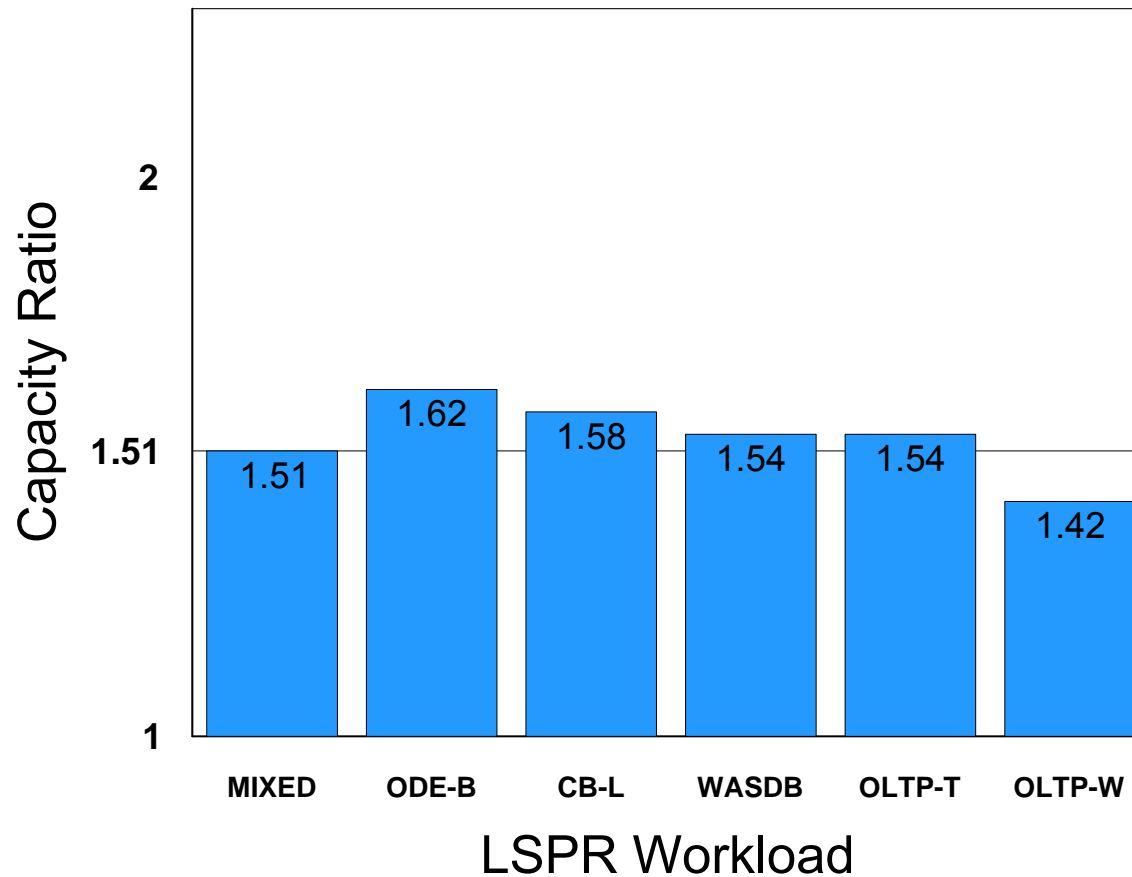

z/OS Capacity Provisioning



Capacity Provisioning Control Center - CPCC



Domain Configuration(s)

Policies

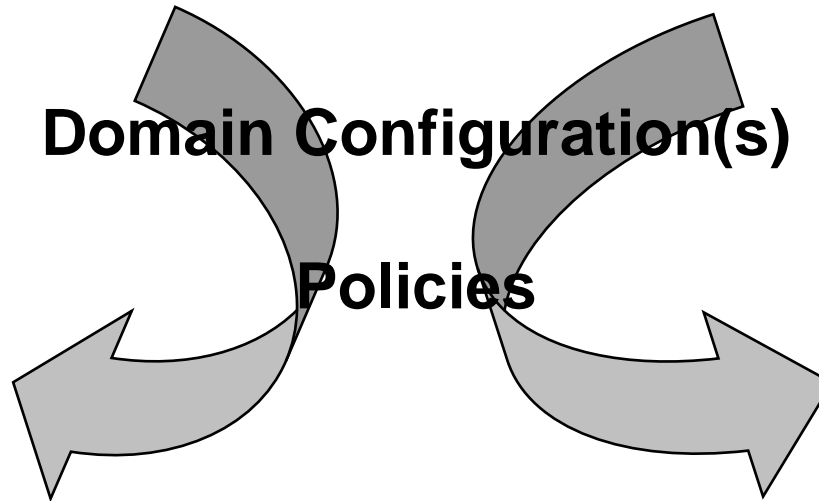

Files

Capacity Provisioning Manager – CPM

Common Information Model - CIM

z10 EC CoD Provisioning Architecture

Capacity Provisioning Manager & Capacity Provisioning Policy

*When
Which work
How much additional capacity*

Implementation Steps

Manual - Analysis - Confirmation - Autonomic

*** Only one On/Off CoD record can be active**

Base Model

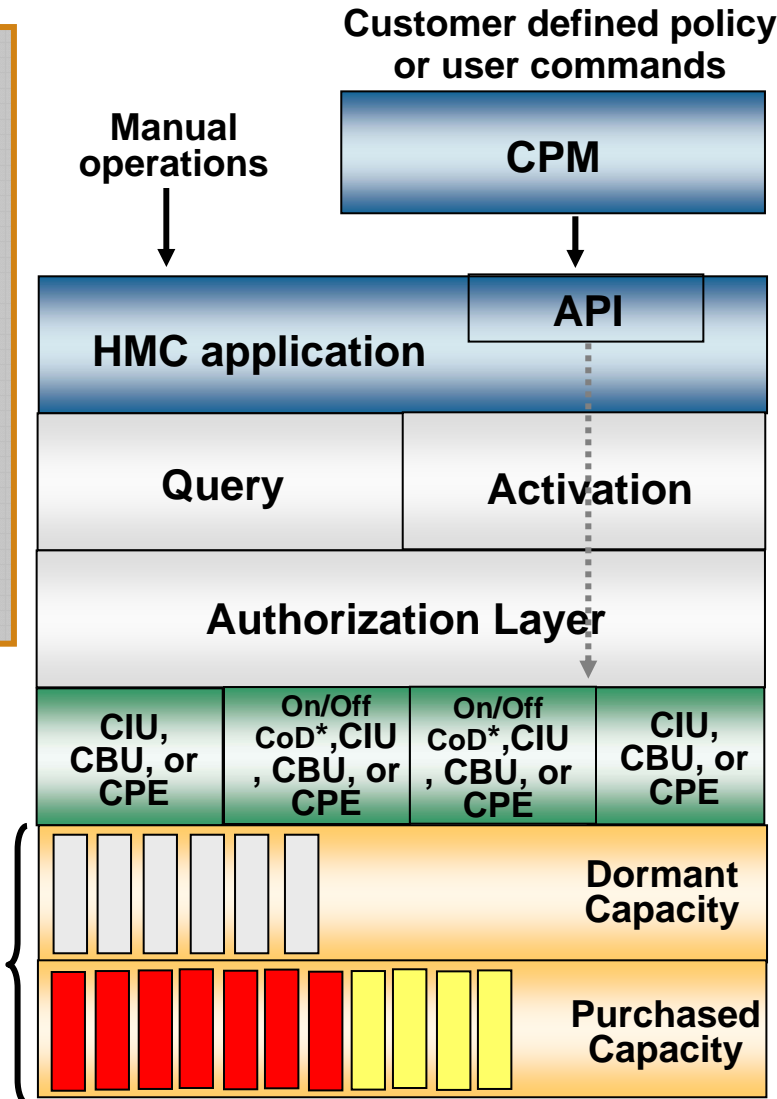

Orders downloaded from Retain/media to SE hard drive



Enforce Terms and Conditions and physical model limitations

Up to 4 records installed and active on the CEC and up to 200 records staged on the SE

Change permanent capacity via CIU or MES order

The Capacity Provisioning Domain

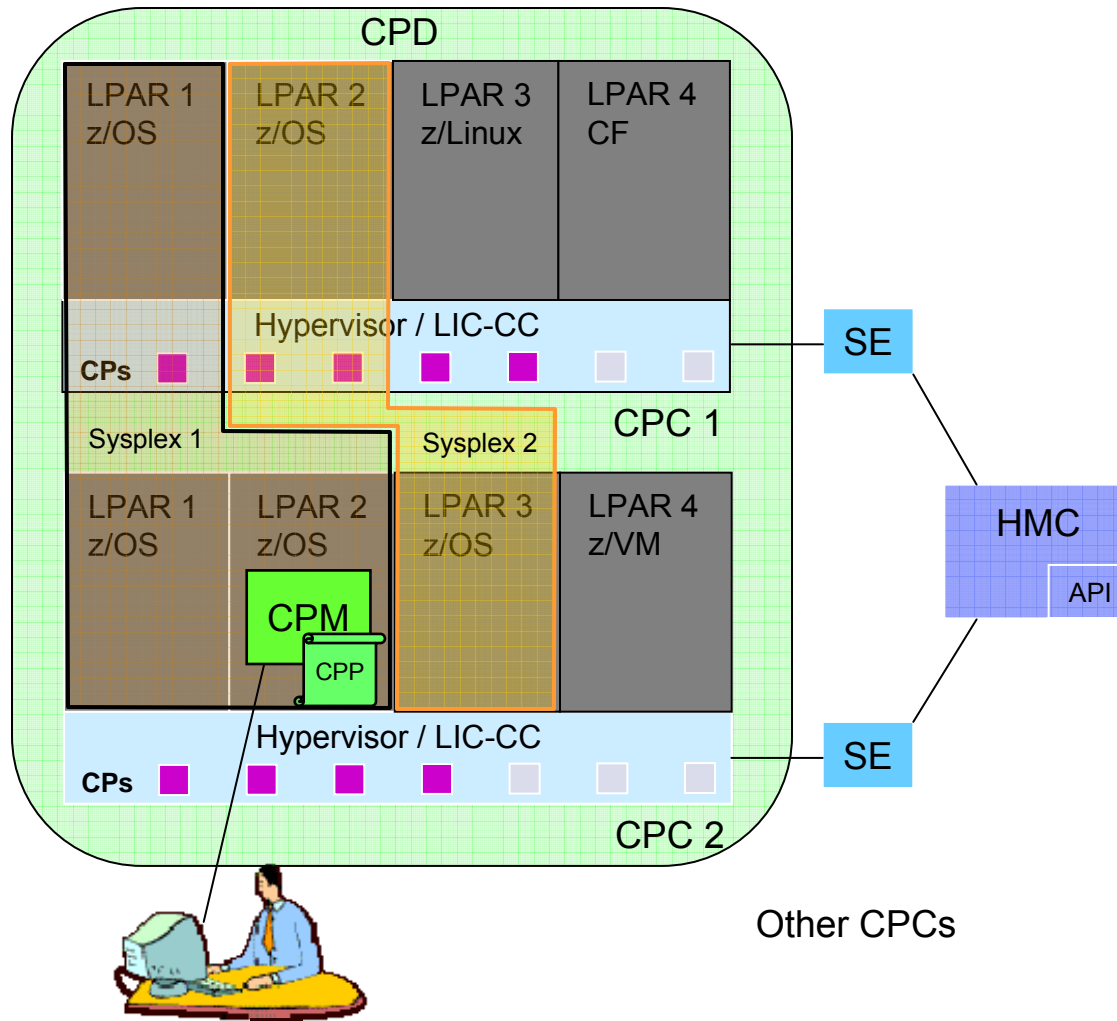

- The domain configuration defines CPCs and z/OS systems that are controlled by a CPM instance
- Sysplexes do not have to be completely contained in a domain but must not belong to more than one domain
- Multiple Sysplexes and hence multiple WLM service definitions may be involved
- One active Capacity Provisioning Policy (CPP) per Domain at a time
 - More than one policy can exist for different purposes

Capacity Provisioning Policy

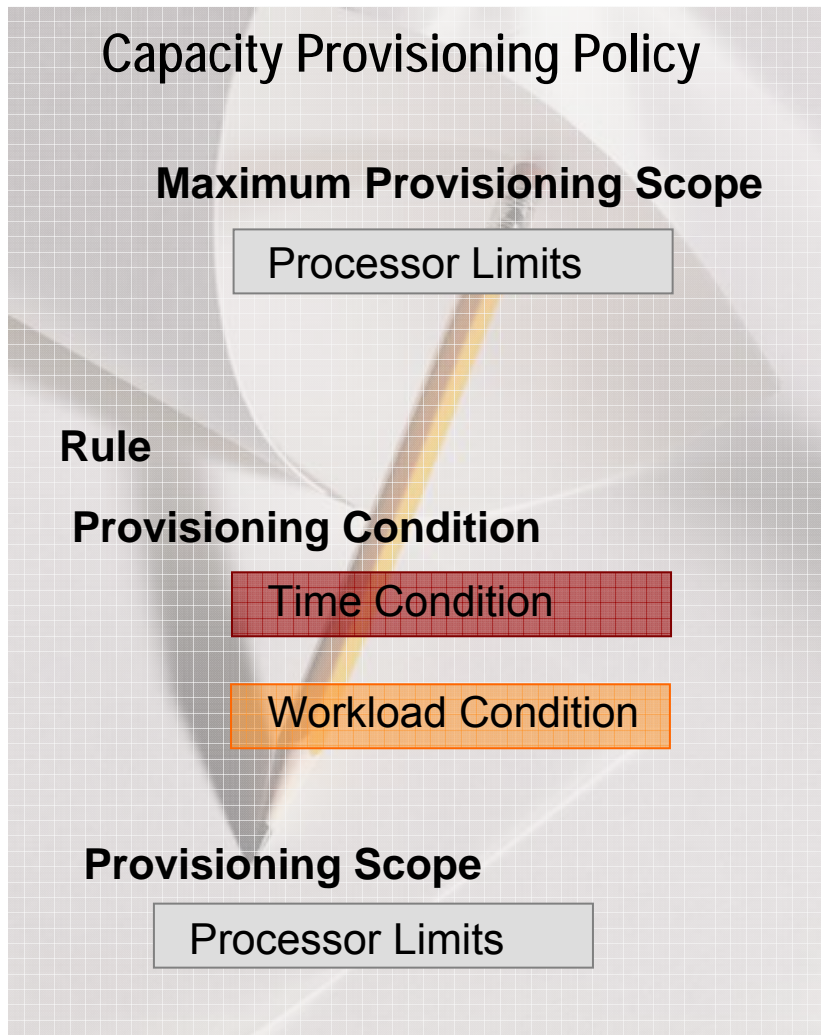

- A policy may consist of multiple rules
 - Based on a variety of things, such as specific applications (bank transactions for example)
- The “Maximum Provisioning Scope” defines the maximum additional capacity that may be activated at any time for all contained rules
 - Expressed in MSUs, zIIPs, zAAPs
- “Provisioning Condition” is simply a group of Time and Workload Conditions that can be referred to
 - WLM Service Class conditions
 - Time Condition (start/deadline/end)
 - Workload (critical workload conditions)
- “Provisioning Scope” defines the maximum capacity that may be activated
 - Expressed in MSUs, zIIPs, zAAPs



z/OS Capacity Provisioning Control Center

File Options Help

Workspace

- Provisioning Manager
- Configurations
- Policies
 - PPSAMPLE
 - Policy Timeline
 - Max. Provisioning Scope
- Rules
 - Rule1
 - Conditions
 - CondSet1
 - Time Con...
 - Workload
 - WorkCc

Workload Condition

Workload Condition Properties

Policy: PPSAMPLE
 Rule: Rule1
 Condition: CondSet1
 Workload Condition: WorkCond1
 Description: A workload condition

* Sysplex: PLEX1
 * System: SYS1

Importance Filters | Included Service Classes | Excluded Service Classes Filter

Importance	Provisioning PI	Duration in min	Deprovisioning PI	Duration in min	PI-Scope
2	1,7	18	1,5	23	Sysplex
3	1,8	21	1,4	22	System

Add Importance Filter | Duplicate Importance Filter | Delete Importance Filter | Apply | Cancel

Messages | Connection Report

Nr.	Severity	Description	Element

Help ?

CPM – Processing Modes

- The CPM operates in any of these four modes:
 - **Manual mode**
 - This is basically a command driven mode where no CPM policy is active
 - **Analysis mode**
 - CPM processes the capacity provisioning policy and informs the operator when a provisioning / deprovisioning action would be due according to the criteria specified in the policy. It is up to the operator either to ignore that information or to perform the up/downgrade manually (using the HMC/SE or the available CPM commands)
 - **Confirmation mode**
 - CPM processes the policy as well as the On/Off CoD record to be used for capacity provisioning. Every provisioning action needs to be authorized (confirmed) by the operator
 - **Autonomic mode**
 - Similar to the preceding mode, except that no human (operator) intervention is required.
- In all modes:
 - Various reports will be available with information about workload and provisioning status, and the rationale for provisioning recommendations
 - User interface through
 - z/OS system console and CP control center application

Shared CPs

- Currently, CPM will only recognize a provisioning action if:
 - the current sum of logical processors is greater than or equal to the target number of physical processors in the respective pool

- Capacity Provisioning does not configure reserved or offline processors online to an LPAR
 - CF CPU(05),ONLINE

Shared CPs

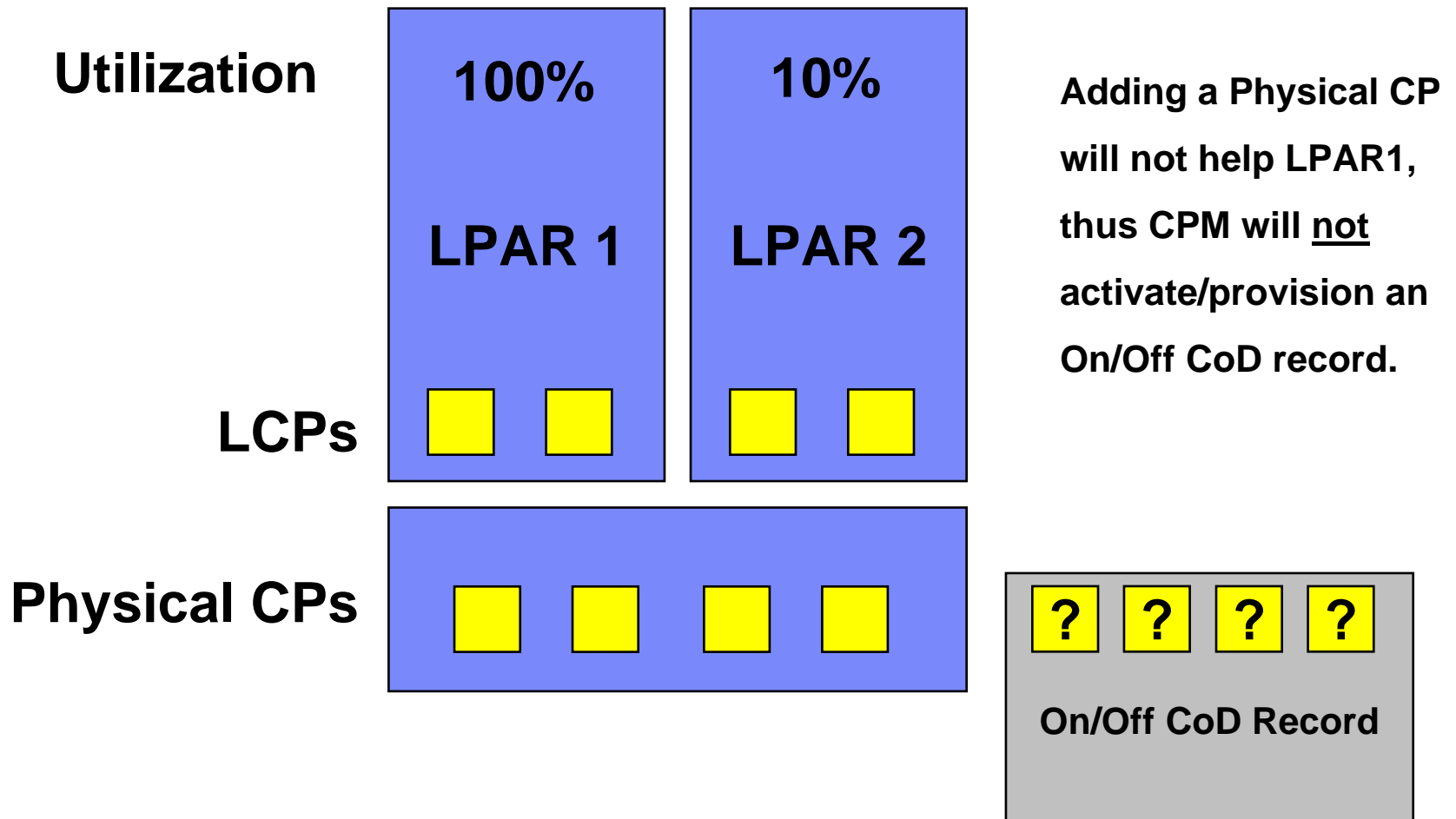

The current sum of logical processors is less than the target number of physical processors in the respective pool.

Shared CPs

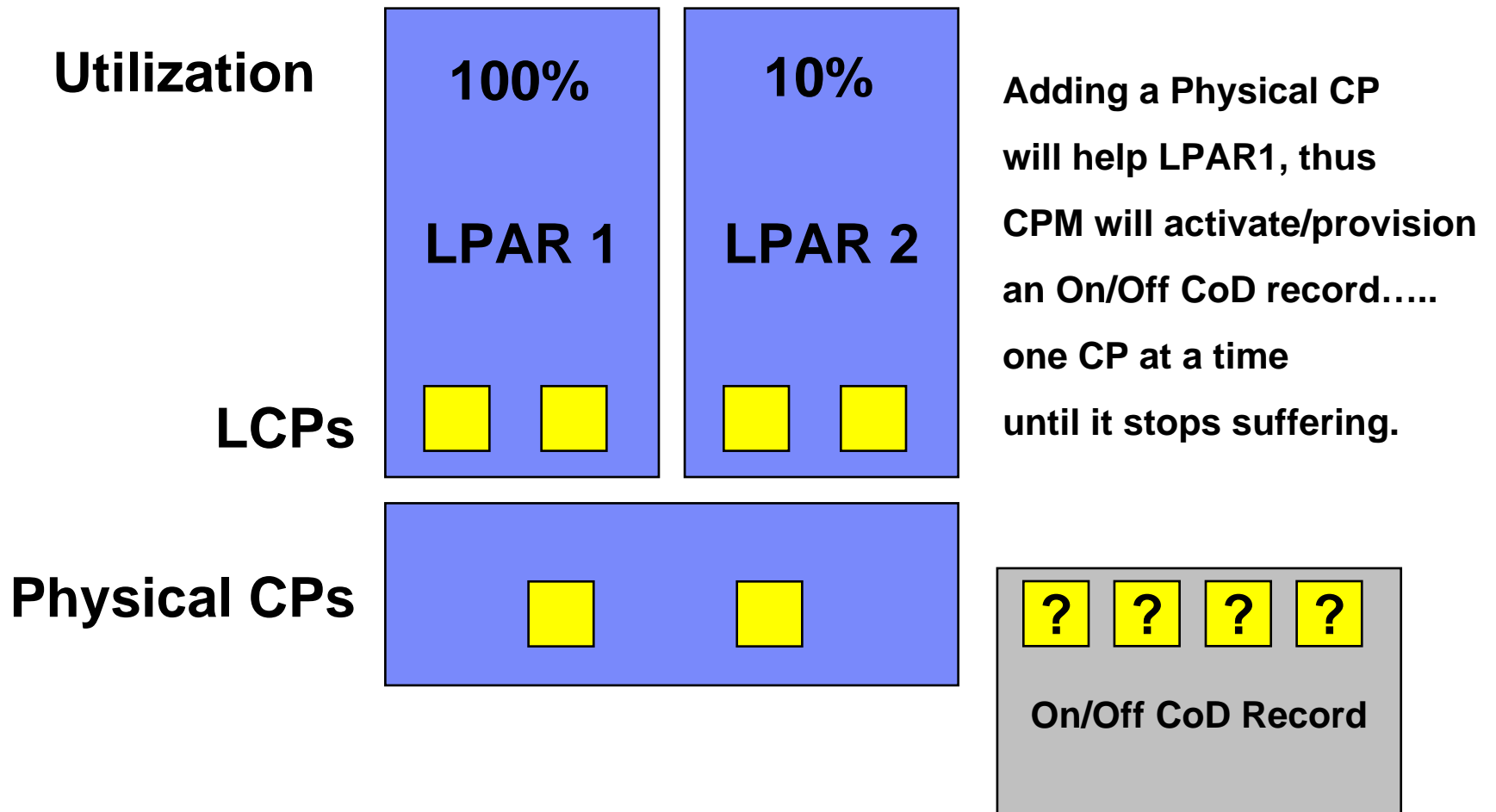

The current sum of logical processors is greater than or equal to the target number of physical processors in the respective pool.

Dedicated CPs

- An “observed” system may run in a shared or dedicated LPAR
- A Dedicated engine can benefit only by increasing the capacity level
 - CPM can only add physical processors to the shared pool
 - CPM cannot help an LPAR defined with dedicated engines by adding physical processors to the shared pool so it will not automatically provision another CP, even if the LPAR is suffering.
 - Dedicated CP capacity-indicator can be increased
- No support for dedicated specialty engines in an LPAR

Supported Environments and Prerequisites

- One or more z10 EC server
 - On/Off Capacity on Demand - enablement feature
- Hardware Management Console
 - TCP/IP connection to HMC must be available
- Multi-LPAR Environments
 - Sufficient number of logical CPs to utilize additional physical CPs
- z/OS Release 9 (on any observed system)
 - RMF or like product
 - RACF or like product
 - CPM not supported when z/OS is a z/VM Guest
- CPCC Workstation
 - An INTEL Pentium® or equivalent processor with 512 MB memory (1 GB recommended)
 - Available disk space 150 MB
 - Microsoft Windows XP Professional - Service Pack 2 or later
 - Screen resolution 1024x768 or higher

z/OS Capacity Provisioning Manager

- Resources

- www.ibm.com/systems/z/cod/
- z10 EC Capacity on Demand – Redbook – SG24-7504
- z/OS Common Information Model User's Guide – SC33-7998
- z/OS MVS Capacity Provisioning Manager User's Guide – SA33-8299
- PR/SM Planning Guide – GA22-7236
- z/OS RMF Report Analysis – SC33-7991
- z/OS MVS Initialization and Tuning Guide – SA22-7591
- z/OS MVS Initialization and Tuning Reference – SA22-7592
- System z Application Programming Interfaces – SB10-7030
- Hardware Management Console Operations Guide (Version 2.10.0) - SC28-6867

Agenda



- Z10 Performance
 - Guidance
 - Capacity Provisioning
- **z/OS V1.10 Preview**
 - Availability
 - Performance
 - Security
 - Management
 - Z10 Support
- DASD Mirroring
 - Basic Hyperswap

z/OS 1.10 Preview*

Improving Usability and Skills

Configuration Assistant, Health Checker & checks, root migration to zFS, PSP processing, CEEPARM syntax checks, DFSMSrmm and DFSMShsm, ISPF, ...

Integrating new Applications and Supporting Industry and Open Standards

HLASM source-level dbx debugging, submit from z/OS UNIX shell, XML offload & validating parser, CEEROPT for batch, NFS V4 enhancements, FTP from Java, Mixed addressing for METAL C, ...

Extending the Network

Hipersockets Multiple Write, TCP/IP and SNA Performance, multiple VLAN support, Auditability enhancements, Load Balancing Subplex support ...

Scalability and Performance

64-way support, HiperDispatcher, Extended Address Volumes, InfiniBand Coupling, 64-bit Common, Improved XCF locking, Metro Mirror devices in Channel Set 1, ...

Optimize your z/OS environment



Improving Availability

Auto-IPL and SADMP, Dynamic JES2 exits, JES2 NJE connection recovery, Basic HyperSwap support, Expanded ASID reuse, SDM offload to zIIP, RACF database integrity, Consoles 2B, DFSMSrmm recovery ...

Self Managing Capabilities

Policy-based capacity provisioning, Contention Mgt Phase 3, PB delays, DATACLAS JCL overrides, More DFSMSrmm/IRMM integration, zIIP CPU Management ...

Enhancing Security

Password phrase exploitation in z/OS UNIX, rlogin, Language Environment, TSO/E, Kerberos, and LDAP; UTF8 CA support in PKI Services, System SSL and Crypto improvements, Custom Fields ...

Statements of Direction (February 2008)*

- IBM intends to expand support for EAV with larger volume sizes and to allow additional data set types to reside in the cylinders after the first 65,520 cylinders.
- z/OS V1.10 is planned to be the last release in which z/OS Communication Server will support these functions:
 - Network Database (NDB)
 - BIND DNS 4.9.3
 - DHCP server
 - Boot Information Negotiation Layer (BINL)
- IBM intends to provide support within z/OS that will allow authorized applications to query, change, and perform basic operational procedures against the installed System z hardware base.
- IBM intends to introduce an IBM z/OS Management Facility, which will be designed to provide the infrastructure, services, and user interfaces to support a browser based graphical user interface needed to support a management console for z/OS.
- **And...** preview for TotalStorage Productivity Center for Replication Basic Edition for System z – to enable Basic HyperSwap

Availability – Sysplex improvements*

Announced/Previewed with z/OS , z/OS V1.10

▪ Simplification

- XCF/ XES health checks promotes sysplex ‘best practices’
- HCM enables you to share configuration packages across sysplex
- z/OS Communications Server - New support to help you coordinate LU name assignments among TN3270 servers in sysplex
- Planned: A z/OS Management Facility for sysplex management support *

▪ Performance/ Availability

- Support for InfiniBand® Coupling links
- Intelligent WLM XCF signaling
- Optimized XCF/ XES CF locking requests
- Consoles enhancements – Improved console serialization (and up to 99 active MCS, SMCS, and subsystem consoles per system in a sysplex)
- Reduced potential of RACF® database error
- Potential to avoid IPL with z/OS UNIX System Services sysplex wide root
- Reduced latency with SFM Auto IPL trigger
- Improved GRS migration
- Load balancing advisor support of subplexes
- Shorter wait for DFSMSHsm CDS backup



Scalability!

Up to 64 processors per server (z10 EC) and up to 32 servers in a sysplex = up to 2,048 engines!

z/OS availability enhancements*

Announced/Previewed with z/OS , z/OS V1.10

- **Improved consoles and message handling**
- **JES2 dynamic exits** – can help avoid JES2 restarts
- **JES2 NJE improvements** – automatically restarts connections
- **Auto IPL** – can reduce latency of operator response time by automatically initiating a dump to capture data for analysis and a restart based on z/OS diagnostics.
- **ASID reuse** – helps reduce planned and unplanned outages by allowing more address spaces to be reused. Exploiters include:
 - CATALOG, LLA, and VLF (available with z/OS V1.9)
 - z/OS UNIX® RESOLVER, TCP/IP, DFSMSrmm™, and TN3270 (with z/OS V1.10)
- **System to react automatically to high fixed storage users**
- **Parallel Sysplex® improvements**
- **Basic HyperSwap solution***
- **z/OS Global Mirror (eXtended Remote Copy, XRC) enabled for zIIP****
- ... and beyond with GDPS® V3.5



**** IBM System z10 Integrated Information Processor and IBM System z9 Integrated Information Processor**

z/OS optimization and management* Announced/Previewed with z/OS, z/OS V1.10

- **Policy based Capacity Provisioning for System z10**
 - A new Capacity Provisioning Manager planned for z/OS V1.10 (and z/OS V1.9 with PTF) plans to monitor System z10 servers and manage z/OS 1.9 and 1.10 systems and add /remove temporary capacity automatically.
 - In the future, z/OS will allow authorized applications to query, change, and perform basic operational procedures against the installed System z hardware base - efficiently deploying server resources when needed*

- **z/OS Workload Manager:**
 - Improved Contention Management
 - Longer promotion, will now promote resource holders to the priority of the highest-priority waiter
 - WLM to manage more address spaces in service class SYSTEM:
 - XCFAS, GRS, SMSPDSE, SMSPDSE1, CONSOLE, IEFSCHAS, IXGLOGR, SMF, and CATALOG (in addition to *MASTER* and WLM)
 - More Performance Block (PB) delays
 - Up to 15 from 5
 - Applications can specify names to replace the default names
 - zIIP CPU management = Manage zIIPs like CPs and zAAPs



Focused performance boost Hardware Decimal Floating Point

- **Decimal arithmetic widely used in commercial and financial applications**
 - Computations often handled in software
 - Avoids rounding and other problems with binary/decimal conversions
- **On IBM System z9 delivered in millicode** - brought improved precision and function
- **On System z10 EC integrated on every core** - giving a performance boost to execution of decimal arithmetic
- **Growing industry support for hardware decimal floating point standardization**
 - Open standard definition led by IBM, endorsed by key ISVs including Microsoft® and SAP
 - Java BigDecimal, C#, XML, C/C++, GCC, DB2® V9, Enterprise PL/1, Assembler
- **z/OS V1.9 Hardware Decimal Floating Point support requires:**
 - High Level Assembler (z/OS V1.8)
 - Enterprise PL/1
 - XL C/C++ with PTF
 - Debug tool (in support of C/C++, PL/1, and HLASM)
 - dbx (in support of C/ C++)
 - DB2 9 for z/OS (allows you to define DPF data in DB2)

Bringing high performance computing benefits to commercial workloads



A z/OS Management Facility *

A Web-browser based management console for z/OS

- Designed to provide the infrastructure, services, and interfaces to support a browser based graphical user interface needed to support a management console for z/OS.
- This initial release of the z/OS Management Facility plans to provide job and process management and Parallel Sysplex management support.

Navigator is tailored to each user's role and responsibilities.

Log of system events. Clicking on an event brings up details.

The screenshot displays the Integrated Solutions Console interface. On the left is a navigation tree with categories like Health, Resources, Workload, Sysplex Resources, Networking, Capacity, Problem, and Settings. The 'Problem' category is circled in blue. The main area shows a table of system events with columns for Event Type, Description, Severity, Date and Time, Sysplex, System, Component, z/OS Release, and Category. Below the table is a 'Health check metrics' section with a 3D bar chart showing counts for Normal, High, Medium, and Low categories.

Event Type	Description	Severity	Date and Time	Sysplex	System	Component	z/OS Release	Category
Abend	Description	Critical	01/09/2007 8:34 PM	PETPLEX	System2	Component	Release	z/OS
Message	Description	Critical	01/09/2007 8:00 PM	PETPLEX	System1	Component	Release	DB2
Dump	Description	Critical	01/09/2007 9:30 PM	PETPLEX	System3	Component	Release	WebSphere
Abend	Description	Warning	01/09/2007 7:46 AM	PETPLEX	System1	Component	Release	z/OS
Abend	Description	Warning	01/09/2007 9:12 PM	PETPLEX	System2	Component	Release	z/OS

z/OS Security Server – RACF

Helping to address security and compliance guidelines*

RACF extensions

- **RACF supports passwords/phrases up to 100 characters - easier to share passwords**
 - 1-8 mixed case characters, 9-13 mixed case characters with new exit (IHPWX11), 14-100 mixed case
 - With z/OS V1.10, exploiters: TSO/E, z/OS UNIX, z/OS UNIX Shell and Utilities, Language Environment, Network Authentication Service support for Kerberos, OpenSSH function of IBM Ported Tools for z/OS (5655-M23) **
 - IBM Tivoli Directory Server (LDAP) for z/OS can be used to start to implement enterprise-wide password synchronization (using, for example, IBM Tivoli Directory Integrator)**
- **Tivoli Directory Server for z/OS**
 - Integrated in the base of z/OS V1.8 – provides sophisticated LDAP services for z/OS, including:
 - Plug in support
 - Improved compatibility with IBM Tivoli Directory Server [distributed]
 - Improved support for RACF
- **RACF support for passtickets (1.7)**
- **RACF support of virtual key rings (1.8)**
- **RACF support for Java user and group SAF admin class (1.9)**
- **RACF (and ICSF) support of PKCS#11 standard (1.9)**

* It is the customer's responsibility to identify, interpret, and comply with laws or regulatory requirements that affect its business. IBM does not represent that its products or services will ensure that the customer is in compliance with the law.

Additional z/OS XML DB2 9 DRDA exploitation of zIIP*

Enterprise Applications that access DB2 9 for z/OS via DRDA[®] over a TCP/IP connection can have portions of eligible SQL/XML requests directed to the zIIP⁽¹⁾

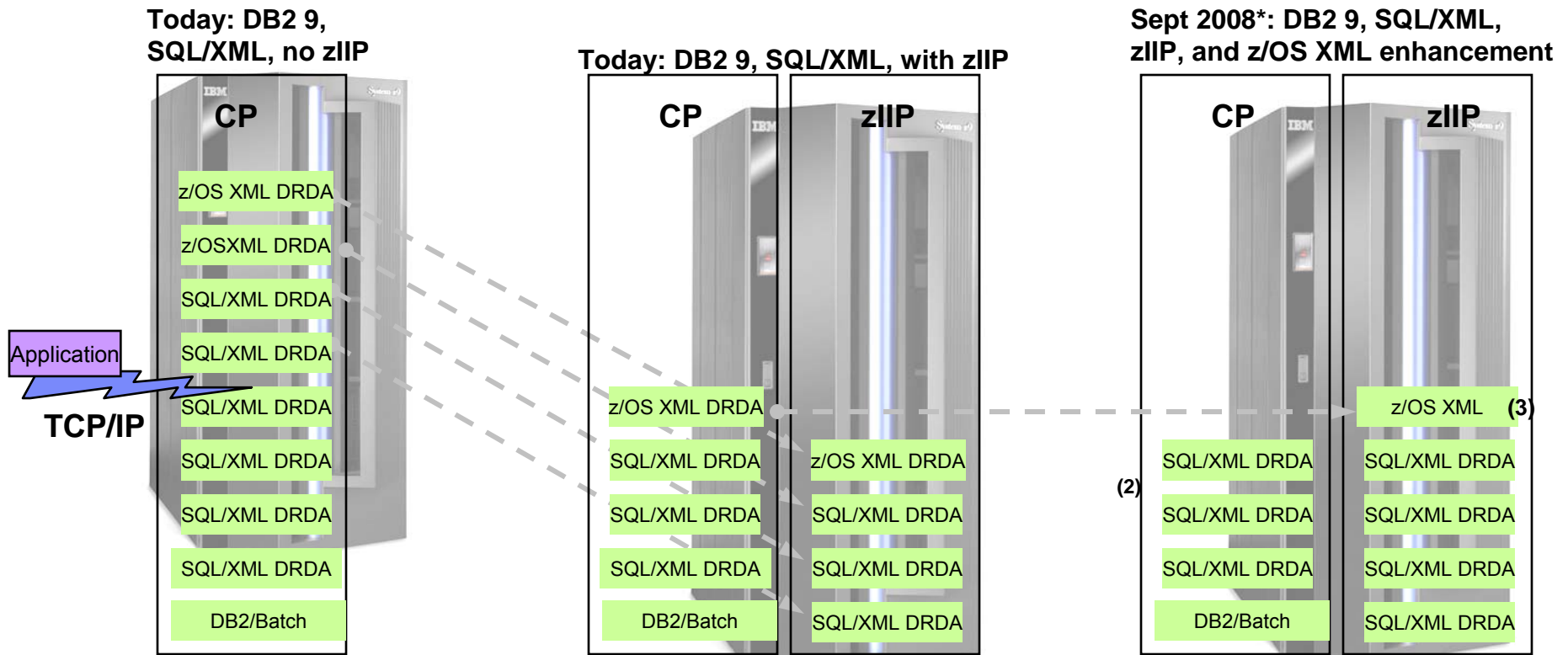

- 1) For illustrative purposes only. Single application only. Actual workload redirects may vary
- 2) DB2 9 for z/OS retains some XML processing (example: XML validation) and executes on CP
- 3) All XML parsing performed by z/OS XML System Services eligible for zIIP*

z/OS XML System Services

In general, what XML workloads can be eligible for zIIP or zAAP

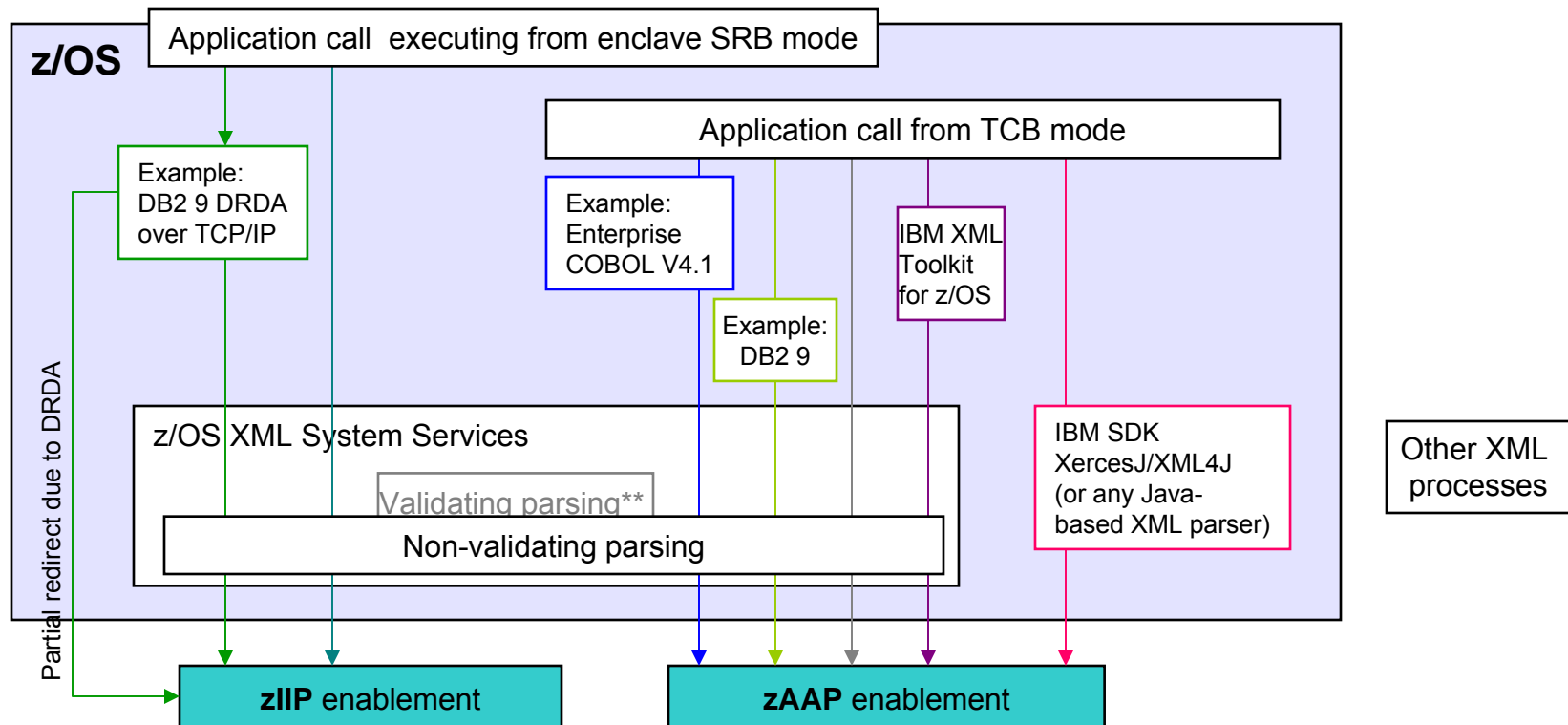

- How much work is eligible for the zAAP will depend on amount of XML data being processed.

** No exploiters for z/OS XML System Services validation parsing, yet. SOD – IBM intends to extend the IBM XML Toolkit for z/OS to include exploitation of z/OS XML System Services validation parsing

XML processing eligible for zAAP and zIIP

Exploitation rolled out over time

Workload	Examples	Available	Redirect	Requirements
z/OS XML System Services, non-validating parsing, – executing in TCB mode	- local applications inserting/ saving XML data, and XML table loads on DB2 9	Yes (with z/OS V1.9 GA)	100% of z/OS XML System Services parsing - eligible for zAAP	DB2 9 New Function Mode C API for z/OS XML System Services available with z/OS 1.9, and z/OS 1.7 & 1.8 with APAR OA18713
z/OS 1.9, or z/OS 1.8 (with OA20308), or z/OS 1.7 (w/ OA16303, OA20308)	- any SW using z/OS XML System Services parsing in TCB	Soon (with XML Toolkit SPE)	same	XML Toolkit for z/OS (5655-J51) V1.9 with SPE (#td)
	- select XML Toolkit for z/OS V1.9 parsing workloads			
z/OS XML System Services, non-validating parsing, executing in enclave SRB mode	- Enterprise COBOL V4.1, using XMLPARSE option	Yes (with COBOL 4.1 GA)	same	Enterprise COBOL V4.1 (5655-J51) z/OS V1.7- V1.9 with OA22777 (SW Announce 207-339).
	- DB2 9 inserting/ saving XML data using DRDA via TCP/IP	Yes (with GA of z/OS V1.8)	Same % as the zIIP-eligible work (DRDA)	z/OS 1.8, or z/OS 1.7 w/ OA16303 DB2 9 New Function Mode
z/OS XML System Services with validating parsing, both enclave SRB and TCB modes.	- any SW (including DB2 9) using z/OS XML System Services in enclave SRB mode	Soon (GA of z/OS V1.10)	100% of z/OS XML System Services parsing eligible for zIIP	z/OS 1.9 and 1.8 (both with APAR #OA22035) DB2 9 NFM
	-- any SW using z/OS XML System Services validating parsing	Soon (GA z/OS V1.10)	100% of z/OS XML System Services validating parsing eligible for zAAP (TCB) or zIIP (enclave SRB).	z/OS V1.10 *
Java-based XML parsing	- select XML Toolkit for z/OS V1.9 workloads	SOD*	TBD	TBD
	- applications using Java-based XML parser in IBM SDK - any SW performing XML parsing/ processing in Java	Yes (with availability of zAAP)	100% of Java-based XML parsing eligible for zAAP	Any z/OS, System z processor with zAAP support.

Taking z/OS storage volumes to the extreme

- **An Extended Address Volume (EAV) is a volume with over 65,280 cylinders**
 - 223 GB volumes initially supported on z/OS V1.10* and IBM System Storage DS8000*
 - Larger volumes are planned to be rolled out over time *
 - First exploiter is VSAM – applications that uses VSAM data sets (including DB2 and CICS®) can benefit from EAV
 - IBM intends to enable other access methods in the future *
- **EAV helps address storage constraints for very large storage**
- **In the future, EAV can help simplify storage management.**
 - Manage fewer, large volumes as opposed to many small volumes
- **DS8000 HyperPAV function complements EAV by allowing the scaling of the I/O rates against a single, larger volume**
- **DS8000 Dynamic Volume Expansion can allow non-disruptive migration to larger volume sizes**

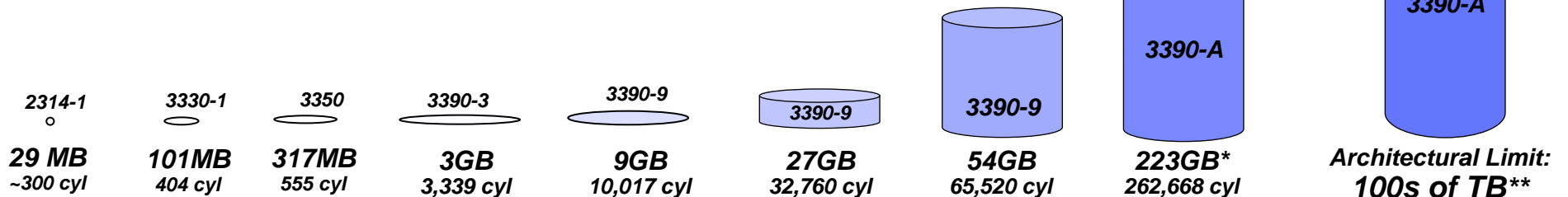

z/OS Planned Roadmap

- XML System Services and specialty engines for 1.7 + 9/07
- zIIP Assisted IPsec for 1.8+ 9/07
- zIIP support 1.6+ 6/06
- Enhanced Crypto Support for 1.7 5/06
- Encryption Facility for z/OS 12/05
- z/OS OMEGAMON® Mgt Console 12/05

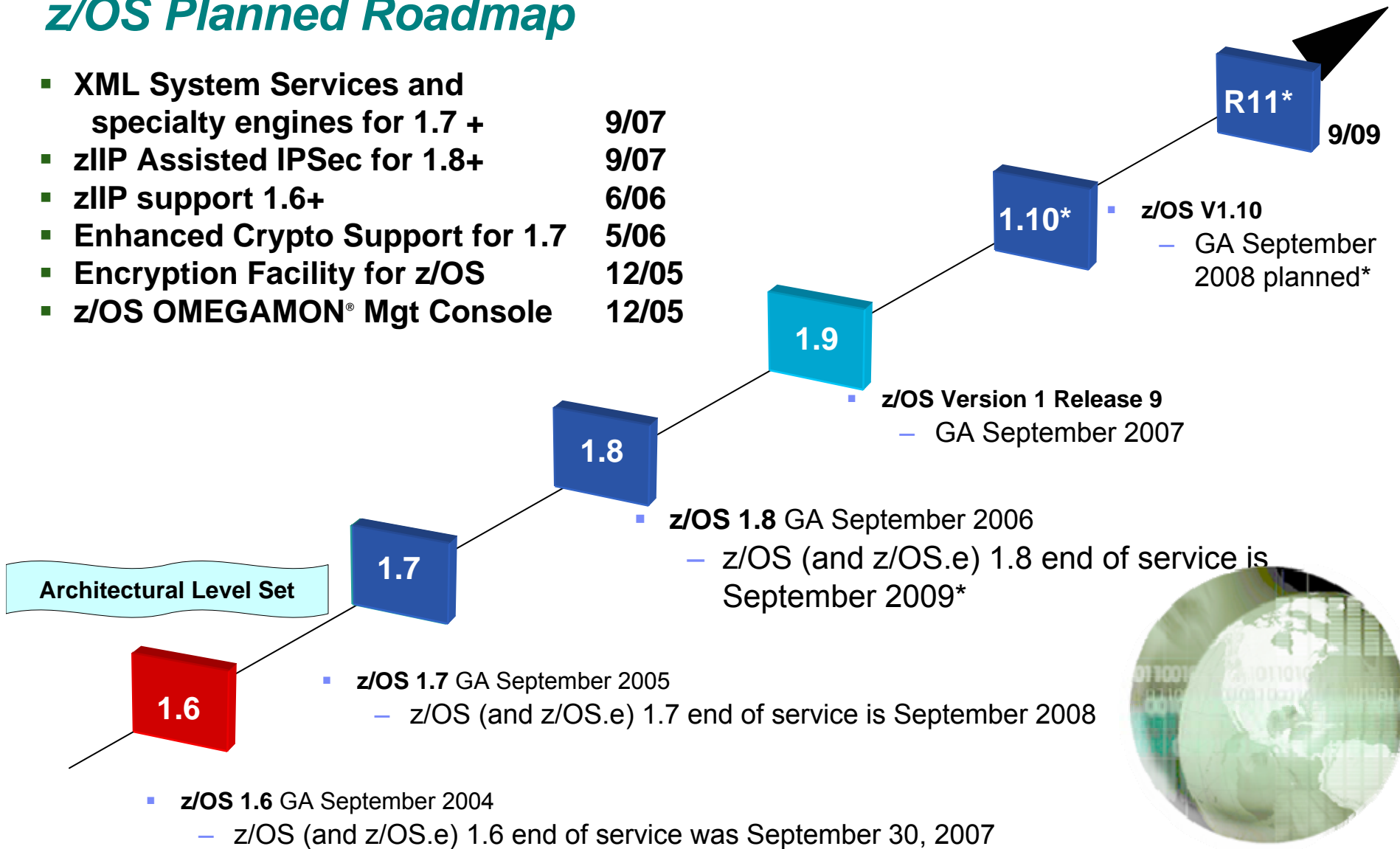

z/OS Support Summary

							End of Service	Coexists with z/OS...	Ship Date
z/OS	z800 z900	z890 z990	z9 EC z9 BC	z10 EC	DS8000 DS6000	TS1120			
R6	X	X	X	X	X	X	9/07	1.8	
R7	X	X	X	X	X	X	9/08	1.9	
R8	X	X	X	X	X	X	9/09*	1.10*	
R9	<u>X</u>	<u>X</u>	<u>X</u>	<u>X</u>	<u>X</u>	<u>X</u>	<u>9/10*</u>	<u>1.11*</u>	<u>9/07</u>
R10*	X	X	X	X**	X	X	9/11*	1.12*	9/08*
R11*	X	X	X	X	X	X	9/12*	1.13*	9/09*

z/OS 1.9 Coexistence-supported releases

Release

z/OS 1.9
z/OS 1.10*
z/OS 1.11*

Coexistence-supported

z/OS 1.7, z/OS 1.8, z/OS 1.9
z/OS 1.8, z/OS 1.9, z/OS 1.10*
z/OS 1.9, z/OS 1.10*, z/OS 1.11*

z/OS.e 1.7, 1.8 supported on z800, z890, and z9 BC only. There is no z/OS.e 1.9.

System z10 EC New Functions and Features

Five hardware models
Faster Processor Unit (PU)
Up to 64 customer PUs
36 CP Subcapacity Settings
Star Book Interconnect
Up to 1,520 GB memory**
Fixed HSA as standard
Large Page (1 MB)***
HiperDispatch
Enhanced CPACF SHA 512, AES 192 and 256-bit keys
Hardware Decimal Floating Point
New Capacity on Demand architecture and enhancements
Capacity Provisioning



(z/OS Support in blue)

6.0 Gbps InfiniBand HCA to I/O interconnect
FICON Enhancements
SCSI IPL included in Base LIC
OSA-Express3 10 GbE (2Q08)
HiperSockets™ enhancements
InfiniBand Coupling Links (2Q08)
STP using InfiniBand (2Q08)
Standard ETR Attachment
FICON LX Fiber Quick Connect
Power Monitoring support
Scheduled Outage Reduction
Improved RAS

** Maximum of 1 TB per LPAR. Maximum supported by z/OS R7 is 512 GB. z/OS R8 and later are designed to support up to 4 TB per image.
 *** z/OS R9 and later required for large page support

z10 EC and z/OS Support for New functions

	z/OS(**)
Basic System z10 EC support	1.7 ¹
HiperDispatch	1.7 ¹
Capacity Provisioning	1.9
Large Page (1MB)	1.9 ¹
HW Decimal Math Support	1.8
CPACF Enhancements	1.7 ¹
STP NTP Client Support	1.7 ¹
OSA-Express3 10 Gbps – CHPID OSD	1.7
HiperSockets Multi Write Facility	1.9
1520 GB per server, 1 TB per LPAR	1.8
4096-bit RSA support	1.7 ¹
64-way support	1.9
InfiniBand Coupling	1.7 ¹

▪ Additional features, service or Web downloads required)

** Note: Please refer to the latest PSP bucket for latest PTFs for z10 EC Compatibility and new functions/features support.

- **Want new z10 EC function? no need to wait for z/OS V1.10**
- **Migrate to z/OS V1.9 today**
 - All z10 EC capabilities available with z/OS V1.9
 - z/OS V1.7 goes out of service September 2008
 - Order z/OS V1.9 today
 - Information on migration
 - Feb 2008 z/OS Hot Topics article www-03.ibm.com/systems/z/os/zos/bkserv/hot_topics.html
 - IBM Education Assistant modules
 - publib.boulder.ibm.com/infocenter/ieduasst/stgv1r0/index.jsp?topic=/com.ibm.iea.zos/zos/1.9/InstallationAndMigration.html
 - Upcoming Migration Conference call
 - Info at: www-03.ibm.com/systems/z/os/zos/index.html
 - Migration workbooks
 - www-03.ibm.com/systems/z/os/zos/installation/
 - Migration Checker
 - www-03.ibm.com/systems/z/os/zos/downloads/#mchecker
 - IBM and IBM Business Partner Services
 - See your representative for more details

Agenda

- Z10 Performance
 - Guidance
 - Capacity Provisioning
- z/OS V1.10 Preview
 - Availability
 - Performance
 - Security
 - Management
 - Z10 Support
- **DASD Mirroring**
 - Basic Hyperswap



z/OS Global Mirror with DS8000 Extended Distance FICON enables protection at less cost

DS8000 Extended Distance FICON

- IBM System z10™ and DS8000 now optimize the FICON pacing to increase the number of commands in flight
- Enables communication over greater distances without substantial reduction to effective data rate
- Supports increased link utilization
- Can significantly reduce the cost of remote mirroring over FICON for z/OS Global Mirror (XRC) solution
 - Eliminates need for more expensive 3rd party protocol-specific channel extenders

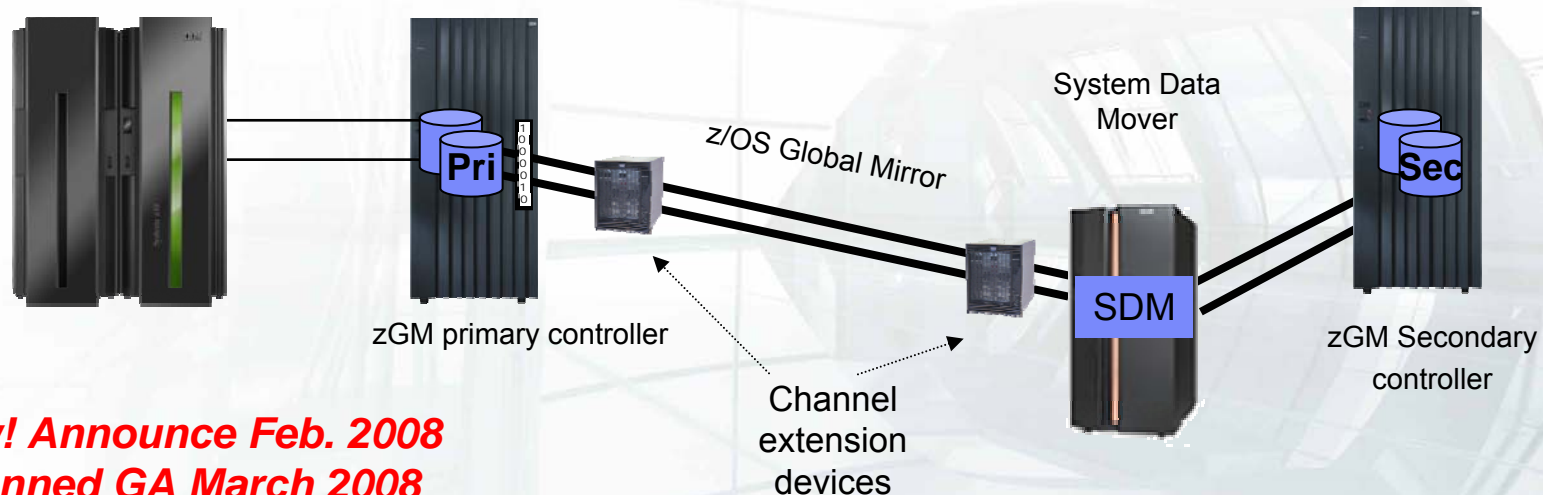

New! Announce Feb. 2008
Planned GA March 2008

z/OS Global Mirror enabled for zIIP: a cost effective mirroring alternative

- **z/OS Global Mirror (formally Extended Remote Copy, XRC) is enabled for the zIIP**
 - ▶ z/OS DFSMS™ allows System Data Mover (SDM) processing to be eligible for the zIIPs
 - ▶ Most SDM processing associated with zGM/XRC is made eligible to run on the zIIP.
- **zIIP assisted z/OS Global Mirror function, can help provide better price performance and improved utilization of resources at the mirrored site.**
 - ▶ DFSMS SDM processing is redirected to a zIIP processor which can lower system utilization at the mirrored site.
- **Available with:**
 - ▶ z/OS V1.10 (when available), or z/OS V1.9 and V1.8 with PTF for APAR #OA23174 (March, 2008)
 - ▶ IBM System Storage DS8000, or any storage controller supporting DFSMS SDM

Reduce utilization, create white space, optimize resources

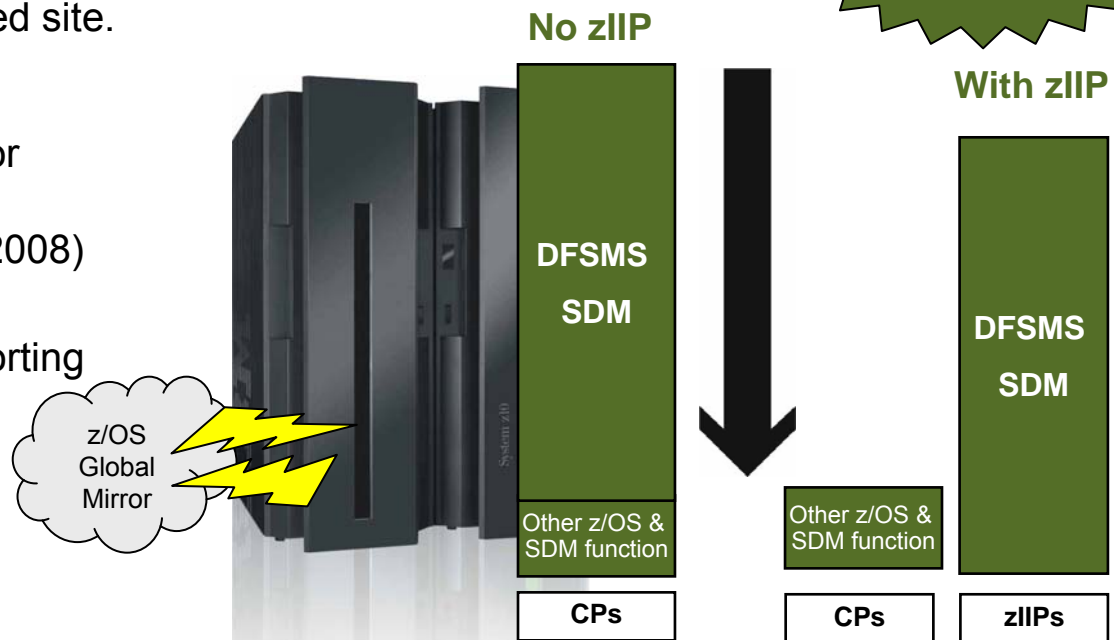

***New! Announce Feb. 2008
Planned GA March 2008***

* For illustrative purposes only, your results will vary.

IBM System Storage DS8000, IBM System z, and GDPS

IBM System Storage z/OS Metro/Global Mirror Incremental Resync

- **A three or two site remote mirroring solution providing protection from data loss for z/OS environments**
 - Uses IBM System Storage Metro Mirror, z/OS Global Mirror (XRC) and GDPS®
 - Production and Metro Mirror copy can be at different sites or in the same site for local/nearby HA/ DR and out of Region DR
 - Note: Three site mirroring with incremental resync using IBM Metro/Global Mirror (PPRC) for open/z is already available and is supported by TPC for Replication
- **Enables High Availability GDPS HyperSwap and Disaster Recovery - swap is automated, seamless and FAST**
- **Incremental resync swaps zGM session volumes & reconnects to remote volumes on a HyperSwap**
- **Helps to speed resynchronization if outage occurs**
- **Reduces amount of data transmitted - only sends changes from Metro Mirror Target to z/OS Global Mirror Target after HyperSwap**

**New! Preview February 2008
Target 2Q08**

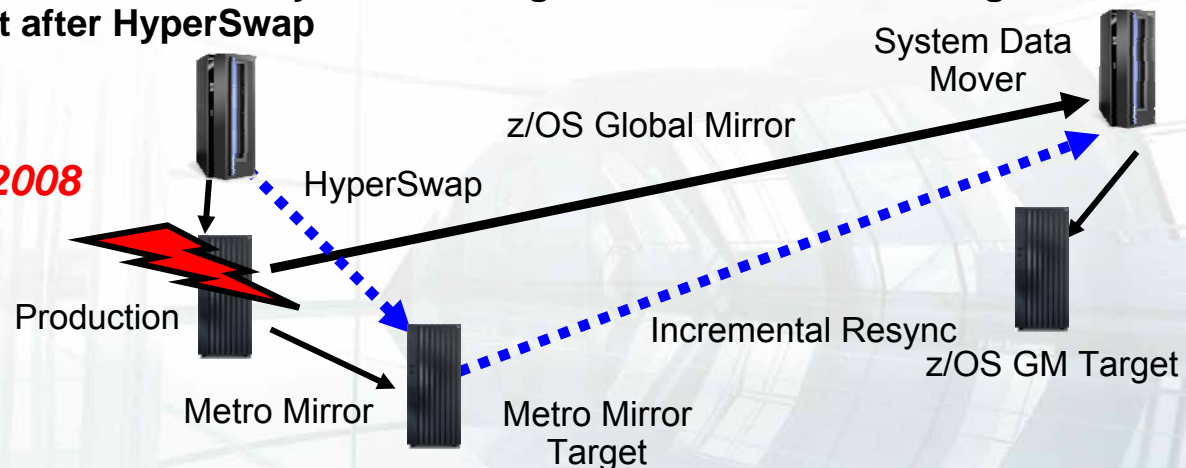

The amount of storage / disk subsystem has dramatically increased to provide improved price/performance and this has increased the business impact when there is a disk subsystem failure.

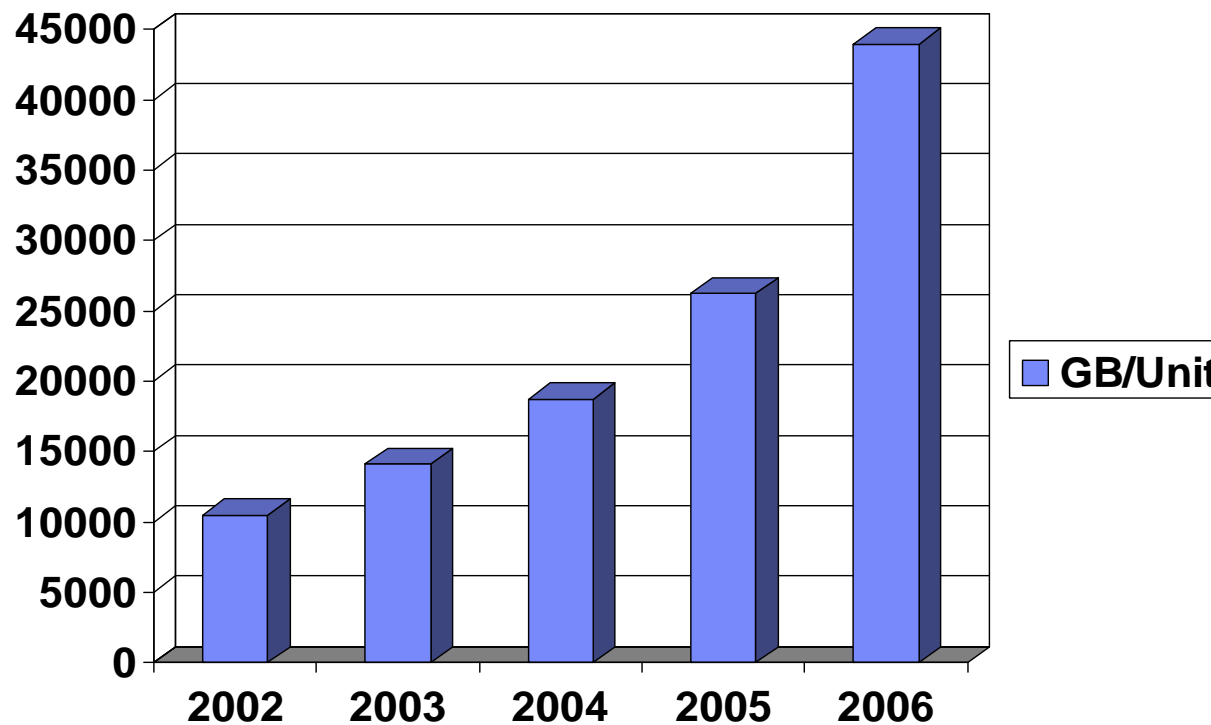

Source: IBM Market Intelligence

Data availability, protection from outages

Basic HyperSwap*

- **Can seamlessly swap between primary and secondary disk volumes**
 - Protects from unplanned disk outages
 - Enables planned fail-over (testing)
 - Management is from z/OS, so GDPS multi-site automation is not required

- **Basic HyperSwap is enabled by IBM TotalStorage® Productivity Center for Replication, and requires:**
 - Planned: IBM TotalStorage Productivity Center for Replication Basic Edition for System z* - intended to have the intuitive z/OS graphical interface and administration capabilities for Basic HyperSwap
 - z/OS V1.9 with maintenance, or z/OS V1.10.
 - IBM System Storage Metro Mirror (DS8000, DS6000™, ESS)
 - Planned: IBM System Services Runtime Environment for z/OS* - intended to provide Web services, or WebSphere® 6.1.0
 - DB2 V8 (or later). Customers without DB2 may use Apache Derby (planned to be available with TotalStorage Productivity Center for Replication Basic Edition for System z).

- **GDPS/PPRC HyperSwap and/or HyperSwap Manager still your first choice for robust multiple site, continuous availability, and DR solutions.**

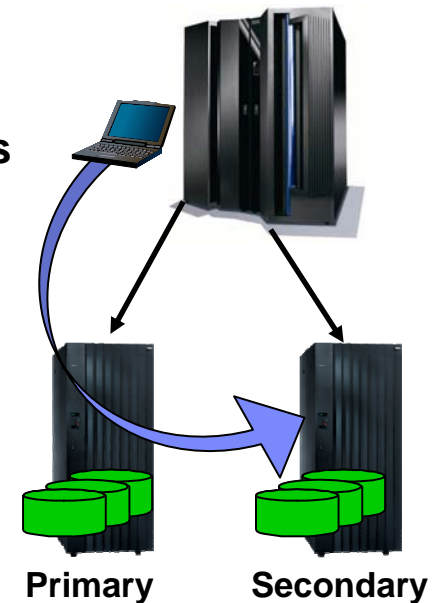

IBM DS8000 Metro Mirror and z/OS 1.9+ Basic HyperSwap

- Ability to swap enterprise class System z Disk Subsystems in seconds.
 - HyperSwap substitutes Metro Mirror secondary for primary device
 - No operator interaction, TPC-R Basic Edition managed
 - Designed to scale to multi-thousands of z/OS volumes
 - Includes volumes with SYSRES, page data sets, catalogs
 - Non-disruptive - applications keep using same device addresses
 - HyperSwap integration with z/OS yielding Higher Availability for z/OS.
 - IBM DiskSubsystem (ESS 800, DS6000 & DS8000)
 - zOS 1.9+ Volumes ONLY.
 - Source & Target Subsystem(s) on Same Data Center Floor

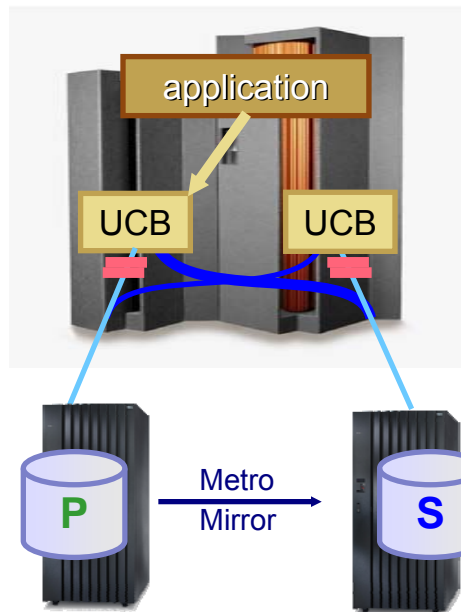

Higher Availability for System z z/OS.

z/OS Basic HyperSwap Functional Overview

- **TPC-R - Single point of control to manage the remote copy configuration**
 - Fully integrated into z/OS 1.9+
 - Cannot HyperSwap zLinux, zVM or Open Systems Data;
 - Systems data will be “frozen” to maintain data consistency if in same TPC-R Session.
- **Unplanned HyperSwap**
 - Masks primary disk subsystem failures by transparently switching to use secondary disks
- **Planned HyperSwap**
 - Provides ability to perform disk maintenance without requiring applications to be quiesced
- **Enables data consistency in the event of failures or disaster**
- **FlashCopy support**
 - Can be initiated via TPC-R prior to resynchronization
- **Status and planned actions**
 - Facilitates Primary/Secondary disk swaps for Planned Disk/Site Maintenance

Basic HyperSwap Prerequisites

▪ **Hardware**

- ESS 800, DS6000, and/or DS8000
 - with advanced copy function, Metro Mirror
 - Host connectivity to both Metro Mirror primary & target devices.

▪ **Software**

- z/OS Release 1.9 + “Basic HyperSwap” SPE
- TPC-R Basic Edition v3.4
 - “Basic Edition” entitled with z/OS v1.9 and beyond
- z/OS DB2 v8.1 and above or Apache Derby Data Base
- SSRE (IBM System Services Runtime Environment) or z/OS WAS v6.1

Note: TPC-R v3.3 (5/07 GA) provided 1st version of TPC-R running on z/OS.

HyperSwap Positioning

■ Basic HyperSwap

- Single site continuous availability function
 - Unplanned failures
 - Planned fail over (testing)
- Aimed at masking disk failures
- IBM Disk Subsystems ONLY (ESS 800, DS6000, DS8000)

■ GDPS/PPRC HyperSwap Manager

- Single site or multiple sites
- Continuous availability and/or Entry level DR solution
- Any Vendors disk subsystem that supports the IBM PPRC Architecture

■ GDPS/PPRC w/HyperSwap

- Full function HyperSwap across multiple Sites for D/R and High Availability.
- Includes Server, Workload & Network Management across sites in addition to Storage
- Supports GDPS/MzGM (GDPS/XRC + GDPS/PPRC HyperSwap) and GDPS/MGM (GDPS/PPRC w/HyperSwap + GDPS/GM) environments.
- Any vendors disk subsystem that supports the IBM PPRC Architecture. (ex. IBM, EMC, HDS (HP & SUN))



GDPS HyperSwap vs Basic HyperSwap [1/2]

Features	GDPS HyperSwap	Basic HyperSwap
Synchronous Mirroring only	Yes	Yes
Provides fast swapping of UCBs ▪ Transparent to application	Yes	Yes
# Sites Supported	Single Site, 2-Site & 3-Site	Single Site Solution Only
Code hardened to avoid hangs ▪ Page faults ▪ Locks	Yes	Yes
Failure management provided by	GDPS	z/OS
Cost	Service Offering	Part of z/OS, but Basic HS Smooth Start offering will be available.
Platforms Supported	z/OS, zVM & zLinux	z/OS
Storage Supported	IBM, EMC, HDS (HP & SUN) (in PPRC mode)	IBM
First Supported	GDPS/PPRC HyperSwap April 2002, HyperSwap Manager 2/15/05.	2008
Software Required	System Automation NetView – HyperSwap Manager has special use Netview & SA at special package price.	SSRE or WAS v6.1 TPC-R v3.4 (entitled) DB2 v8.1 or Apache DB



GDPS HyperSwap vs Basic HyperSwap [2/2]

Features	GDPS HyperSwap	Basic HyperSwap
Requires K-system	Yes	No, TPC-R Addr Space
Supports XCF Couple Dataset	No	No
Supports HyperSwap with zGM (MzGM)	Yes	No
Supports HyperSwap Global Mirror (MGM)	Yes	No
HyperSwap Options (Resync, Suspend FO/FB, Data Migration)	Yes, Yes, Yes	Yes, Yes, Yes
Supports protection against IPL against wrong set of disks	Yes	No
Supports Planned & Unplanned FO/FB	Yes	Requires Full TPC-R for site switch, otherwise TPC-R Basic Edition.
Supports TDMF Compatibility	Yes	No
zOS Support Levels	zOS 1.7+	zOS 1.9+
Supports FlashCopy before Resync	Yes	No
Supports a "Data Freeze"	Yes	Yes for HS triggers but No for mirroring failures on a Basic HyperSwap Session. Target Volumes not consistent in this case.





zEND



THANK YOU!

Gord Neill
System z
Advanced Technical Support
IBM Canada Ltd
gneill@ca.ibm.com

IBM Systems

© 2007 IBM Corporation